

8928 JEWELLA AVE, SHREVEPORT, LOUISIANA 71118

LONG JOHN SILVER'S

LEGAL JURISDICTION: CITY OF SHREVEPORT DEPARTMENT OF PUBLIC WORKS
 BUILDING CODE: 2021 INTERNATIONAL BUILDING CODE (IBC)
 ACCESSIBILITY: 2021 EDITION OF LIFE SAFETY NFPA 101
 MECHANICAL: 2021 INTERNATIONAL MECHANICAL CODE (IMC)
 PLUMBING: 2021 INTERNATIONAL PLUMBING CODE (IPC)
 ELECTRICAL: 2020 NATIONAL ELECTRICAL CODE (NEC)
 FUEL GAS: 2021 INTERNATIONAL FUEL GAS CODE (IFGC)

BUILDING AREA: 2,190 S.F. GROSS
 2,090 S.F. NET
 SEATING: 62 INTERIOR
 OCCUPANCY: A2
 TYPE CONSTRUCTION: TYPE VB - UNPROTECTED

PROJECT SUMMARY

PHONE LINES: 25 PAIR CABLE IN 2" CONDUIT
 ELECTRIC SERVICE: 400 AMPS / 3 PHASE / 120-208 VOLT
 GAS: 1,326,500 BTUH
 WIND SPEED: NOMINAL 104 MPH
 EARTHQUAKE: S = .066
 ROOF LIVE LOAD: SDS = .114

CIVIL

NO.	DESCRIPTION	ISSUE
C-0.0	TITLE SHEET	
C-1.0	CIVIL NOTES	
C-1.1	SITE DETAILS	
C-1.2	SITE DETAILS	
C-1.3	SITE DETAILS	
C-1.4	SITE DETAILS	
C-2.0	EXISTING CONDITIONS	
C-2.1	DEMO PLAN	
C-3.0	SITE PLAN	
C-3.1	PAVING PLAN	
C-3.2	GRADING PLAN	
C-3.3	STRIPING PLAN	
C-3.4	VEHICLE ROUTE PLAN	
C-4.0	UTILITY PLAN	
C-5.0	SWPPP PLAN	
C-5.1	SWPPP DETAILS	
C-5.2	SWPPP DETAILS	
L-1.0	LANDSCAPING PLAN	
ES-1.1	SITE LIGHTING PLAN	

**ARCHITECTURE
ENGINEERING**

LJS

LAND INVESTMENT SERVICES, INC.
 2672 West State Road #25
 Ouedo, Louisiana 70765
 Phone: (504) 244-0402
 Facsimile: (504) 244-9419

21430 Palm Beach Blvd
 Ave. FL 33500
 Phone: (813) 944-4400
 Facsimile: (813) 933-8828

ADAM J. BARNEY
 LAREGNO: 35092

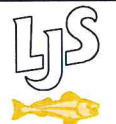

8928 JEWELLA AVE,
 SHREVEPORT,
 LOUISIANA 71118

- A. ALL WORK SHALL CONFORM TO THE 2012 INTERNATIONAL BUILDING CODE, AND ALL OTHER APPLICABLE CODES, STANDARDS, AND REGULATIONS OF THE TOWN OF SHREVEPORT, LOUISIANA.
- B. IT IS INTENDED THAT A COMPLETE OCCUPIABLE BUILDING PROJECT IS PROVIDED.
- C. THE GENERAL CONDITIONS OF THE CONTRACT FOR CONSTRUCTION (A.I.A. A201 LATEST EDITION) ARE A PART OF THESE CONTRACT DOCUMENTS. A COPY IS ON FILE AT THE ARCHITECT'S OFFICE.
- D. DO NOT SCALE THESE DRAWINGS. VERIFY ALL DIMENSIONS AND CONDITIONS IN THE FIELD. ANY DISCREPANCIES IN THESE DRAWINGS SHALL BE BROUGHT TO THE ATTENTION OF THE ARCHITECT PRIOR TO STARTING WORK.
- E. ALL PROPOSED SUBSTITUTIONS SHALL BE APPROVED BY THE LONG JOHN SILVERS CORPORATE BRAND DESIGNER OR CONSTRUCTION MANAGER, IN WRITING, PRIOR TO INSTALLATION.
- F. RETAIN THE PROJECT GEOTECHNICAL ENGINEER TO PROVIDE OBSERVATION AND TESTING SERVICES DURING THE GRADING (INCLUDING UTILITY TRENCHES) AND FOUNDATION PHASE OF CONSTRUCTION AS RECOMMENDED IN THE GEOTECHNICAL REPORT. ALL TESTING AND INSPECTION REPORTS, INCLUDING FINAL SUMMARY LETTER, SHALL BE SUBMITTED TO THE BUILDING DEPARTMENT AND OWNER. G.C. SHALL CERTIFY PAD ELEVATION PRIOR TO START OF FOUNDATION WORK.
- G. SUBMIT, PAY FEES AND OBTAIN ALL PERMITS ASSOCIATED WITH THE PROJECT EXCEPT GENERAL BUILDING PERMIT. THIS INCLUDES, BUT IS NOT LIMITED TO ELECTRICAL, MECHANICAL, PLUMBING, FIRE SPRINKLER, HOOD ANSUL, OR OTHER RELATED FIRE PERMITS, ENCROACHMENT PERMIT, ETC. OWNER WILL PAY FOR "CONNECTION FEES" ASSOCIATED WITH UTILITY PERMITS. PAY FOR TEMPORARY FACILITIES FEES AS REQUIRED TO COMPLETE THE WORK IN A TIMELY MANNER.
- H. PROVIDE EACH SUBCONTRACTOR WITH A COMPLETE AGENCY-PERMITTED DRAWING SET AT TIME OF CONSTRUCTION.
- I. ALL ABBREVIATIONS INCLUDED FOLLOW INDUSTRY STANDARDS. CONTACT ARCHITECT IF ANY ABBREVIATIONS ARE NOT CLEAR.
- J. GC SHALL SUPPLY AND INSTALL ALL ASPECTS OF THE PROJECT DESCRIBED IN THIS DRAWING SET UNLESS OTHERWISE NOTED. SEE SCOPE OF WORK FOR EXCEPTIONS.
- K. GRAPHIC AND WRITTEN INFORMATION ON DRAWINGS SHALL BE COORDINATED WITH ALL TRADES PRIOR TO INSTALLATION.
- L. ALL MATERIALS STAGED TO BE USED FOR CONSTRUCTION SHALL BE PROTECTED FROM EXCESSIVE MOISTURE. IF THEY ARE EXPOSED TO MOISTURE THEY SHOULD BE ADEQUATELY DRIED AND INSPECTED FOR COMPLIANCE WITH MINIMUM QUALITY STANDARDS BEFORE ENCAPSULATED INTO THE BUILDING.

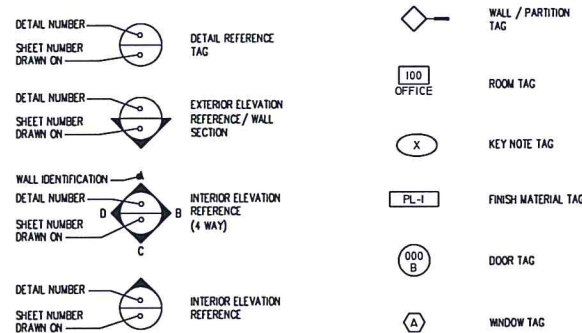

GENERAL DRAWING SYMBOLS

OWNER:
 LJS OPCO ONE, LLC
 10350 ORMSBY PARK PLACE, STE 300
 LOUISVILLE, KY 40223
 CONTACT: COREY JENKINS
 PHONE: 423-438-1416

CIVIL ENGINEER:
 LIS
 2572 WEST SR-426, STE 2064
 OVIEDO, FL 32765
 CONTACT: JUSTIN CHAMBERLAIN
 PHONE: 321-244-0402

ARCHITECT:
 LIS
 2572 WEST SR-426, STE 2064
 OVIEDO, FL 32765
 CONTACT: JUSTIN CHAMBERLAIN
 PHONE: 321-244-0402

PROJECT DIRECTORY

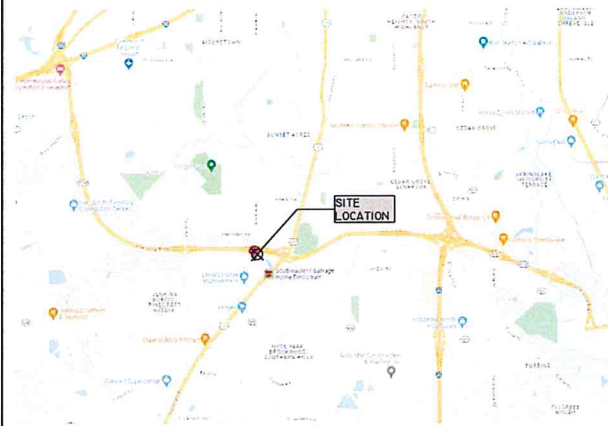

VICINITY MAP

**EXECUTIVE
DIRECTOR
APPROVAL**

3-24-24
Date

Justin Chamberlain
By

MPC SIGNATURE LINE DATE

PROJECT GENERAL NOTES

SHEET INDEX

REVISION		
No.	DATE	DESCRIPTION

DWG DATE: XX-XX-XXXX
 DRAWN BY: CB / JC
 PROJECT No.: 2023-050
 DWG TITLE:

TITLE SHEET

SHEET No.
C-0.0

GENERAL NOTES:

- CONTRACTOR IS SPECIFICALLY CAUTIONED THAT THE EXISTING UTILITIES SHOWN ON THIS DRAWING ARE APPROXIMATE AND BASED ON PARTIAL INFORMATION PROVIDED BY THE UTILITY OWNERS. CONTRACTOR IS RESPONSIBLE FOR CONTACTING "STATE ONE CALL" (811) AND VERIFYING THE LOCATION OF ALL UTILITIES IN THE AREA PRIOR TO CONSTRUCTION. EXTREME CAUTION SHALL BE USED TO NOT DAMAGE EXISTING UTILITIES. THE EXISTING UTILITY INFORMATION SHOWN IS NOT TO BE RELIED UPON AS BEING EXACT OR COMPLETE. CONTRACTOR SHALL CONTACT ENGINEER AND OWNER WHEN LOCATIONS OF UTILITIES ARE NOT IN GENERAL VICINITY SHOWN ON DRAWINGS. BOUNDARY/PROPERTY INFORMATION IS SHOWN FOR INFORMATIONAL PURPOSES ONLY.
- THE CONTRACTOR IS RESPONSIBLE FOR REPAIRING ANY DAMAGE TO EXISTING FACILITIES, ABOVE OR BELOW GROUND, THAT MAY OCCUR AS A RESULT OF THE WORK PERFORMED BY THE CONTRACTOR OR SUBCONTRACTORS.
- IT IS THE CONTRACTOR'S RESPONSIBILITY TO BECOME FAMILIAR WITH THE PERMIT AND INSPECTION REQUIREMENTS SPECIFIED BY THE VARIOUS GOVERNMENTAL AGENCIES AND THE ENGINEER. THE CONTRACTOR SHALL OBTAIN ALL NECESSARY PERMITS PRIOR TO CONSTRUCTION AND SCHEDULE INSPECTIONS ACCORDING TO AGENCY INSTRUCTIONS/REQUIREMENTS.
- SAFETY:
 - DURING THE CONSTRUCTION AND/OR MAINTENANCE OF THIS PROJECT, ALL SAFETY REGULATION ARE TO BE ENFORCED. THE CONTRACTOR OR HIS REPRESENTATIVE SHALL BE RESPONSIBLE FOR THE CONTROL AND SAFETY OF THE TRAVELING PUBLIC AND THE SAFETY OF HIS/HER PERSONNEL.
 - LABOR SAFETY REGULATIONS SHALL CONFORM TO THE PROVISIONS SET FORTH BY OSHA IN THE FEDERAL REGISTER OF THE DEPT. OF TRANSPORTATION.
 - THE MINIMUM STANDARDS AS SET FORTH BY THE STATE DEPARTMENT OF TRANSPORTATION SHALL BE FOLLOWED IN THE DESIGN, APPLICATION, INSTALLATION, MAINTENANCE AND REMOVAL OF ALL TRAFFIC CONTROL DEVICES, WARNING DEVICES AND BARRIERS NECESSARY TO PROTECT THE PUBLIC AND CONSTRUCTION PERSONNEL FROM HAZARDS WITHIN THE PROJECT LIMITS.
 - ALL TRAFFIC CONTROL MARKINGS AND DEVICES SHALL CONFORM TO THE PROVISIONS SET FORTH IN THE MANUAL ON UNIFORM TRAFFIC CONTROL DEVICES PREPARED BY THE U.S. DEPARTMENT OF TRANSPORTATION FEDERAL HIGHWAY ADMINISTRATION.
 - ALL SUBSURFACE CONSTRUCTION SHALL COMPLY WITH THE "TRENCH SAFETY ACT", THE CONTRACTOR SHALL ENSURE THAT THE METHOD OF TRENCH PROTECTION AND CONSTRUCTION IS IN COMPLIANCE WITH THE OCCUPATIONAL SAFETY AND HEALTH ADMINISTRATION (OSHA) REGULATIONS.
- IT SHALL BE THE SOLE RESPONSIBILITY OF THE CONTRACTOR TO COMPLY WITH AND ENFORCE ALL APPLICABLE SAFETY REGULATIONS. THE ABOVE INFORMATION HAS BEEN PROVIDED FOR THE CONTRACTOR'S INFORMATION ONLY AND DOES NOT IMPLY THAT THE OWNER OR ENGINEER WILL INSPECT AND/OR ENFORCE SAFETY REGULATIONS.

GRADING NOTES:

- THE ENTIRE CONSTRUCTION AREA SHALL BE STRIPPED OF TOPSOIL AND ORGANIC MATERIAL AND PROOF ROLLED PRIOR TO PLACEMENT OF FILL. AREAS OF UNSTABLE SOIL SHALL BE REMOVED AND REPLACED AS DIRECTED BY THE ENGINEER. SUBGRADE SOIL SHALL BE TESTED BY A QUALIFIED TESTING LABORATORY TO DETERMINE THE PLASTICITY INDEX PRIOR TO PREPARATION OF BASE.
- EXCESS FILL MATERIAL SHALL BE STOCKPILED ON SITE AT A LOCATION APPROVED BY OWNER AND ENGINEER. STOCKPILED MATERIAL MUST BE PROTECTED FROM EROSION. ANY EXCESS MATERIAL MUST BE SPREAD INTO 8" LOOSE LIFTS AND COMPACTED @ 95% STANDARD PROCTOR DENSITY UNLESS IT IS STOCKPILED.
- THE CONTRACTOR SHALL CLEAR AND GRUB THE ENTIRE LIMITS OF CONSTRUCTION AND REMOVE ALL ORGANIC MATERIALS. ALL DISTURBED AREAS MUST BE SEEDED AND MULCHED, SODDED, OR PLANTED WITH OTHER APPROVED LANDSCAPED MATERIAL IMMEDIATELY FOLLOWING CONSTRUCTION.
- ALL EXISTING DEBRIS WITHIN CONSTRUCTION LIMITS (ABOVE OR BELOW GROUND), CONSTRUCTION DEBRIS AND OTHER WASTE MATERIAL SHALL BE DISPOSED OF OFF-SITE BY THE CONTRACTOR IN ACCORDANCE WITH APPLICABLE REGULATORY AGENCY REQUIREMENTS.
- NATIVE MATERIALS OBTAINED FROM SITE EXCAVATIONS MAY BE USED FOR FILL IN PARKING AREAS PROVIDED THAT THEY MEET THE REQUIREMENTS FOR SELECT FILL SPECIFIED BY THE GEOTECH REPORT. NO NATIVE MATERIALS ARE TO BE USED AS FILL WITHIN FIVE FEET OF BUILDING AREA UNLESS AUTHORIZED BY GEOTECHNICAL ENGINEER.
- SELECT FILL MATERIAL PLACED DURING CONSTRUCTION SHALL MEET THE REQUIREMENTS FOR TYPE OF MATERIAL, PLACEMENT AND COMPACTION SPECIFIED IN THE GEOTECH REPORT.
- SELECT FILL SHALL CONSIST OF HOMOGENOUS SOILS FREE OF ORGANIC MATTER AND DEBRIS; A PLASTICITY INDEX BETWEEN FIVE (5) AND FIFTEEN (15); A LIQUID LIMIT OF THIRTY-FIVE (35) OR LESS; AND NO GREATER THAN 60% FINER THAN 200 MESH SIEVE AT PLUS OR MINUS 2% OF OPTIMUM MOISTURE. SELECT FILL SOURCE SHALL BE APPROVED PRIOR TO PLACEMENT OF FILL WITHIN THE SITE.
- SELECT FILL SHALL BE PLACED ON PREPARED SUBGRADE IN 8" LOOSE LIFTS AND COMPACTED TO 95% STANDARD PROCTOR DENSITY.
- CONTRACTOR SHALL BREAK UP SLOPED SURFACE STEEPER THAN 4:1 SO THAT FILL MATERIAL WILL BOND WITH EXISTING SURFACE.
- THE CONTRACTOR IS RESPONSIBLE FOR COORDINATING APPLICABLE TESTING WITH THE SOILS ENGINEER. COMPACTION TESTS WILL BE REQUIRED FOR EACH LIFT. UPON COMPLETION OF WORK THE SOILS ENGINEER WILL SUBMIT CERTIFICATIONS TO THE OWNER AND OWNER'S ENGINEER STATING THAT ALL REQUIREMENTS HAVE BEEN MET.
- A QUALIFIED TESTING LABORATORY SHALL PERFORM ALL TESTING NECESSARY TO ASSURE COMPLIANCE OF THE IN-PLACE MATERIALS AS REQUIRED BY THE PLANS, THE VARIOUS AGENCIES AND PERMIT CONDITIONS. SHOULD ANY RETESTING BE REQUIRED DUE TO THE FAILURE OF ANY TESTS TO MEET THE REQUIREMENTS, THE COSTS OF ALL SAID RETESTING WILL BE BORN BY THE CONTRACTOR.
- CONTRACTOR SHALL GRADE ALL GRASSED AREAS TO DRAIN TO EXISTING OR PROPOSED CATCH BASINS OR DRAINAGE PIPE INLETS. AREAS ADJACENT TO BUILDING SHALL BE GRADED TO DRAIN AWAY FROM STRUCTURES AND PREVENT PONDING.
- CONTRACTOR SHALL PROVIDE FILL AS REQUIRED TO TIE TO EXISTING GRADE AT THE PERIMETER OF CURBS AND BUILDINGS AT A SLOPE OF 4:1 (MAXIMUM) FROM THE TOP OF CURB OR 6 INCHES BELOW TOP OF BUILDING FOUNDATION.
- CONTRACTOR SHALL PROVIDE AND MAINTAIN ALL EROSION CONTROL MEASURES AS OUTLINED IN CONSTRUCTION. NO MUD OR SILT SHOULD BE ALLOWED TO ENTER DRAINAGE DITCHES OR ADJACENT PROPERTY. SHOULD MUD BE TRACKED ONTO LOCAL ROAD(S), THE CONTRACTOR SHALL BROOM AND CLEAN THE PAVEMENT IMMEDIATELY TO PREVENT UNSAFE DRIVING CONDITIONS.
- ANY SITUATION OF ADJACENT PROPERTY OR DRAINAGE FACILITIES SHALL BE REMOVED PRIOR TO FINAL ACCEPTANCE BY OWNER.
- ALL EROSION CONTROL MEASURES SHOULD BE PROPERLY INSTALLED PRIOR TO BEGINNING OF CONSTRUCTION. NO MUD OR SILT SHOULD BE ALLOWED TO ENTER DRAINAGE DITCHES OR ADJACENT PROPERTY. SHOULD MUD BE TACKED ONTO LOCAL ROAD(S) THE CONTRACTOR SHALL BROOM AND CLEAN THE PAVEMENT IMMEDIATELY TO PREVENT UNSAFE DRIVING CONDITIONS.

UTILITY NOTES:

- CONTRACTOR SHALL NOTIFY ENGINEER, OWNER AND WATER DEPARTMENT 48 HOURS PRIOR TO BEGINNING WORK ON ANY NEW SANITARY SEWER TO SCHEDULE INSPECTION OF THE WORK.
- PRIOR TO COMMENCING WORK WHICH REQUIRES CONNECTING PROPOSED FACILITIES TO EXISTING LINES OR APPURTENANCES, THE CONTRACTOR SHALL VERIFY THE LOCATION AND ELEVATION(S) OF EXISTING CONNECTION POINT(S) AND NOTIFY THE OWNER'S ENGINEER OF ANY CONFLICTS OR DISCREPANCIES.
- SANITARY SEWERS SHOULD ALWAYS CROSS UNDERNEATH WATER MAINS. INSTALLATION OF SANITARY SEWERS AT CROSSINGS OF WATER MAINS SHALL BE PERFORMED SO AS TO PROVIDE A MINIMUM VERTICAL DISTANCE OF 18 INCHES BETWEEN THE INVERT OF THE UPPER PIPE AND THE CROWN OF THE LOWER PIPE WHENEVER POSSIBLE. THE CROSSING SHALL BE ARRANGED SO THAT THE SEWER JOINTS AND WATER JOINTS SHALL BE EQUIDISTANT FROM THE POINT OF CROSSING WITH NO LESS THAN 10 FEET BETWEEN ANY TWO JOINTS.
- A MINIMUM 10 FOOT HORIZONTAL SEPARATION SHALL BE MAINTAINED BETWEEN ANY TYPE OF SEWER (INCLUDING FORCE MAINS) AND EXISTING OR PROPOSED WATER MAINS IN PARALLEL INSTALLATIONS WHENEVER POSSIBLE. THE DISTANCE FOR SEPARATION SHALL BE MEASURED EDGE TO EDGE.
- ALL PVC SEWER PIPE SHALL BE SOLID WALL POLY VINYL CHLORIDE PIPE AND COMPLY WITH ASTM D-3034 AND ALL APPLICABLE ASTM DOCUMENTS AS COVERED IN SECTION NO. 2 OF ASTM D-3034.
- ALL GRAVITY SEWERS MUST BE SDR 35 PVC. ELASTOMERIC GASKET JOINTS SHALL BE UTILIZED FOR PVC PIPE AND SHALL COMPLY WITH ASTM F-477, ASTM D-3034, & ASTM F-679. JOINTS SHALL COMPLY WITH ASTM D-3212.
- ALL GRAVITY SEWER PIPING SHALL BE SUBJECT TO A VISUAL INSPECTION BY THE OWNER. THE CONTRACTOR SHALL NOTIFY THE OWNER 48 HOURS IN ADVANCE TO SCHEDULE INSPECTION(S).
- THE CONTRACTOR SHALL PERFORM AN INFILTRATION/EXFILTRATION TEST (LOW PRESSURE AIR) ON THE GRAVITY SEWERS IN ACCORDANCE WITH LOCAL AUTHORITY REQUIREMENTS. SAID TEST ARE TO BE CERTIFIED BY THE ENGINEER OF RECORD AND SUBMITTED TO THE REGULATORY AGENCY FOR APPROVAL.
- NOT USED
- LOCAL ENERGY PROVIDER TO PROVIDE ELECTRICAL TRANSFORMER, CABLE, STREET LIGHTS, AND CONDUIT FOR ELECTRICAL SERVICE TO TRANSFORMER. CONTRACTOR TO BURY CONDUIT IN LOCATION SHOWN HEREON. CONTRACTOR TO CONTACT ENERGY PROVIDER PRIOR TO START OF CONSTRUCTION TO COORDINATE ELECTRICAL SERVICE.

DRAINAGE NOTES:

- ALL CONCRETE USED FOR PAVEMENT, CURB, DRAINAGE STRUCTURES AND MISCELLANEOUS CONSTRUCTION SHALL ATTAIN A MINIMUM COMPRESSIVE STRENGTH OF 3500 PSI AT 28 DAYS.
- ALL DRAINAGE STRUCTURES SHALL BE IN ACCORDANCE WITH LDOTD STANDARD SPECIFICATIONS FOR ROADS AND BRIDGES, LATEST EDITION, UNLESS NOTED OTHERWISE ON PLANS.
- ALL DRAINAGE STRUCTURE GRATES AND COVERS WITHIN PAVED AREAS SHALL BE TRAFFIC RATED FOR H-20 LOADINGS.
- CATCH BASIN TOPS SHALL BE CAST IN PLACE. PRECAST CONCRETE CATCH BASIN INVERTS WILL BE ALLOWED.
- CONTRACTOR TO COMPLETE TOPS OF CATCH BASIN ONCE ADJACENT GRADES HAVE BEEN ESTABLISHED TO ENSURE THAT FINAL CATCH BASIN INLET IS SET AT THE APPROPRIATE ELEVATION.
- PIPE LENGTHS SHOWN ARE APPROXIMATED AND TO CENTER OF DRAINAGE STRUCTURES.
- IF ANY EXISTING STRUCTURES TO REMAIN ARE DAMAGED DURING CONSTRUCTION IT SHALL BE THE CONTRACTOR'S RESPONSIBILITY TO REPAIR AND/OR REPLACE THE EXISTING STRUCTURE AS REQUIRED TO RETURN IT TO EXISTING CONDITIONS OR BETTER.
- ALL STORM SEWER PIPING ENTERING CONCRETE STRUCTURES SHALL BE GROUTED TO ASSURE THE CONNECTION POINT IS WATERTIGHT.
- THE CONTRACTOR SHALL BE RESPONSIBLE FOR PROTECTING EXCAVATIONS AGAINST COLLAPSE AND WILL PROVIDE BRACING, SHEETING, OR SHORING AS NECESSARY.
- DEWATERING METHODS SHALL BE USED AS REQUIRED TO KEEP TRENCHES DRY WHILE PIPE AND APPURTENANCES ARE BEING PLACED.
- THE STORM DRAINAGE SYSTEM SHALL BE SUBJECT TO A VISUAL INSPECTION BY THE OWNER'S ENGINEER PRIOR TO THE PLACEMENT OF BACKFILL. CONTRACTOR TO NOTIFY THE ENGINEER 48 HOURS IN ADVANCE TO SCHEDULE INSPECTION.
- THE CONTRACTOR SHALL MAINTAIN AND PROTECT FROM MUD, DIRT, DEBRIS, ETC. THE STORM DRAINAGE SYSTEM UNTIL FINAL ACCEPTANCE OF THE PROJECT. THE STORM SYSTEM WILL BE REINSPECTED BY THE OWNER'S ENGINEER PRIOR TO APPROVAL. THE CONTRACTOR MAY BE REQUIRED TO RECLEAN PIPES AND INLETS PRIOR TO ACCEPTANCE.
- ALL STORM SEWER PIPE SHALL BE ADS N-12 HIGH DENSITY POLYETHYLENE CORRUGATED PLASTIC PIPE (HDPE) AS NOTED HEREON OR APPROVED EQUAL. PIPE SHALL BE DOUBLE WALL SMOOTH INTERIOR WITH INTEGRATED GASKETED SPLICES & BELL ENDS AND INSTALLED IN ACCORDANCE WITH ASTM D2321.
- ALL HDPE SPLICES AND CONNECTIONS TO REDUCERS SHALL BE ACCOMPLISHED BY THE USE OF ADS SPLIT COUPLERS AND DOUBLE WIDE MAR MAC POLYSEAL REPAIR COUPLERS, UNLESS OTHERWISE NOTED. (OR APPROVED EQUAL)
- ALL MIXED MATERIAL SPLICES SHALL BE ACCOMPLISHED BY THE USE OF ADS SPIGOT ADAPTERS AND DOUBLE WIDE MAR MAC POLYSEAL REPAIR COUPLERS, UNLESS OTHERWISE NOTED. (OR APPROVED EQUAL)
- ALL DRAINAGE PIPE JOINTS SHALL BE WATER TIGHT.
- ALL DRAINAGE PIPING SHALL BE BACKFILLED IN ACCORDANCE WITH THE DETAILS CONTAINED HEREIN.
- CONTRACTOR SHALL NOTIFY STATE DEPARTMENT OF TRANSPORTATION PRIOR TO PERFORMING ANY WORK IN STATE RIGHT-OF-WAY.
- WHEN WORKING IN STATE RIGHT-OF-WAY, CONTRACTOR SHALL FOLLOW STATE REQUIREMENTS FOR CONSTRUCTION SIGNING.

WATER NOTES:

- CONSTRUCTION OF WATER FACILITIES TO BEGIN UPON APPROVAL BY THE OAK RIDGE PUBLIC WORKS DEPARTMENT.
- WATER LINES SHALL BE INSTALLED WITH A MINIMUM 36 INCHES COVER OVER THE TOP OF PIPE. LINES INSTALLED BENEATH ROAD SURFACES SHALL BE A MINIMUM OF 48 INCHES BENEATH THE SURFACE OF THE ROAD.
- ALL WATER LINE FITTINGS SHALL CONFORM WITH NSF/ANSI 372 AND SHALL BE INSTALLED WITH ROMAC GRIP RINGS.
- ALL WATER PIPING, JOINTS, HYDRANTS, AND APPURTENANCES SHALL COMPLY WITH NSF/ANSI 372.
- ALL TRANSITIONS BETWEEN PE AND PVC PIPE SHALL BE ACCOMPLISHED WITH "HARVEY ADAPTERS".
- ALL WATER LINES (INCLUDING SERVICE TUBING) SHALL BE INSTALLED WITH 10 GA TYPE TW STRANDED COPPER LOCATOR WIRE AT TEN O'CLOCK OR TWO O'CLOCK POSITION AND EXTENDED INTO METER AND VALVE BOXES. ALL SPLICES IN LOCATOR WIRE SHALL BE MADE WITH COPPER "3M" BRAND DIRECT BURY SPLICE KIT MODEL DBR.
- THE NEW WATER MAIN SHALL BE PRESSURE TESTED PRIOR TO THE TIE-IN OPERATIONS. ALL REPAIRS AND RE-TESTING SHALL BE MADE PRIOR TO TIE-IN. PRESSURE TEST SHALL BE IN ACCORDANCE WITH AWWA C600. THE MAXIMUM ALLOWABLE LEAKAGE SHALL BE 10 GALLONS PER INCH OF PIPE DIAMETER PER MILE OF PIPE FOR 24 HOURS. THE TEST PROCEDURE SHALL BE 4 HOURS. THE CONTRACTOR SHALL FURNISH GAUGES, METERS, WATER, TOOLS, LABOR, EQUIPMENT, AND OTHER MATERIALS NECESSARY TO CONDUCT THE TESTS. THE ENGINEER SHALL BE NOTIFIED AT LEAST 48 HOURS IN ADVANCE OF TESTS.
- FOLLOWING THE ACCEPTANCE OF THE HYDROSTATIC TEST, ALL NEW WATER LINES INCLUDING APPURTENANCES SHALL BE DISINFECTED IN ACCORDANCE WITH AWWA C651 (LATEST REVISION) AND LOCAL CODE.
- WHILE THE DISINFECTANT IS BEING APPLIED TO ANY SECTION OF THE SYSTEM, THE WATER SHALL BE ALLOWED TO ESCAPE AT ALL EXTREMITIES OF THIS SECTION UNTIL THE PRESENCE OF CHLORINE IS EVIDENT BY MEASURING WITH AN ORTHOTOLIDIN TEST KIT FURNISHED BY THE CONTRACTOR.
- BACTERIOLOGICAL TESTS SHALL BE CONDUCTED BY A STATE CERTIFIED LABORATORY AND MUST INDICATE NEGATIVE FOR COLIFORM BACTERIA PRIOR TO USE OF THE WATER MAINS TO CONVEY WATER TO THE PUBLIC. IF BACTERIOLOGICAL TESTS INDICATE INSUFFICIENT DISINFECTION AT THE COMPLETION OF THE TESTING AND FLUSHING OF THE SYSTEM, THE PROCEDURE SHALL BE REPEATED UNTIL PROPER DISINFECTION IS ACHIEVED.
- ALL MATERIALS SHALL BE IN COMPLIANCE WITH THE FEDERAL SAFE DRINKING WATER ACT AND THE LOCAL CODE AND SHALL BE CONSIDERED EITHER LOW OR NO LEAD.

STRIPING & SIGNAGE NOTES:

- ALL TRAFFIC CONTROL DEVICES SHALL MEET MUTCD REQUIREMENTS (LATEST EDITION).
- ALL ROADWAY MARKINGS SHALL BE OF A THERMOPLASTIC MARKING MATERIAL AND COMPLY WITH STATE DEPARTMENT OF TRANSPORTATION STANDARD SPECIFICATIONS, LATEST EDITION.

STREET SURFACE & BASE COURSE:

- SOIL CLASSIFICATION (SUB-BASE AND BASE MATERIAL)
- OPTIMUM MOISTURE/DENSITY OF BASE MATERIAL (STANDARD PROCTOR, ASTM D 1557)
- ATTEBURG LIQUID LIMITS AND PLASTICITY INDEX (SUB-BASE AND BASE MATERIAL)
- STABILIZATION REQUIREMENTS (PERCENT LIME AND/OR CEMENT) (SUB-BASE LIME AND BASE LIME AND/OR CEMENT)
 - SUB-GRADE STABILIZATION THE DEVELOPER SHALL STABILIZE ALL SUB-GRADE SOILS WITH A PLASTICITY INDEX OF 20 OR MORE UNLESS A CIVIL ENGINEER RECOMMENDS AN ALTERNATIVE TECHNIQUE SUCH AS GEO FABRIC. SUB-GRADE SOILS EVALUATION SHALL GENERALLY APPLY TO THE TOP EIGHT INCHES OF SOIL MEASURED DOWN FROM THE PROPOSED SUB-GRADE SURFACE. THE DEVELOPER SHALL COMPACT ALL SUB-GRADE AND INDIVIDUAL LAYERS OF BASE AND PAVING MATERIALS TO 95 PERCENT RELATIVE DENSITY, TO BE CONFIRMED BY STANDARD PROCTOR TEST (ASTM D 1557).
 - ALTERNATIVE SURFACES IN EVENT THE DEVELOPER ELECTS TO USE ALTERNATIVE SURFACES SUCH AS PORTLAND CEMENT CONCRETE, DESIGN OF THE SUB-BASE, BASE COURSE, AND CONCRETE SHALL BE PROVIDED TO THE PUBLIC WORKS DIRECTOR BY A LICENSED CIVIL ENGINEER FOR APPROVAL, PRIOR TO START OF WORK.
 - ACCEPTANCE NO STREET WILL BE ACCEPTED FOR PERPETUAL MAINTENANCE BY THE HOMEOWNER'S ASSOCIATION WITHOUT COMPLETE COMPLIANCE WITH THESE PROCEDURES AND THE WRITTEN ACCEPTANCE OF THE HOMEOWNER'S ASSOCIATION. THE DATE OF SUCH WRITTEN ACCEPTANCE SHALL BEGIN A ONE YEAR WARRANTY PERIOD DURING WHICH TIME THE DEVELOPER IS COMPLETELY RESPONSIBLE FOR MAINTENANCE AND STREET REPAIRS. APPROXIMATELY 30 DAYS PRIOR TO EXPIRATION OF THE WARRANTY PERIOD, THE HOMEOWNER'S SHALL SCHEDULE A WARRANTY INSPECTION WITH THE DEVELOPER.
- THIS PROJECT DID NOT INCLUDE ANY GEOTECHNICAL DATA. PAVEMENT DESIGN MAY BE VALUED ENGINEERED WITH A GEOTECHNICAL REPORT.

EXECUTIVE DIRECTOR APPROVAL

3-28-24
Date By

LIS ARCHITECTURE ENGINEERING
 LIS ARCHITECTURE ENGINEERING, LLC
 2572 Wood Stone Road, Suite 200
 Metairie, LA 70002
 Phone: (504) 885-3244
 Fax: (504) 885-3628

ADAM J. BARNEY
 LA REG. NO. 33092

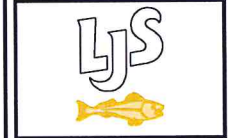

**8928 JEWELLA AVE,
 SHREVEPORT,
 LOUISIANA 71118**

REVISION		
No.	DATE	DESCRIPTION

DWG DATE: XX-XX-XXXX
 DRAWN BY: CB / JC
 PROJECT No.: 2023-050

DWG TITLE:
CIVIL NOTES

SHEET No.
C-1.0

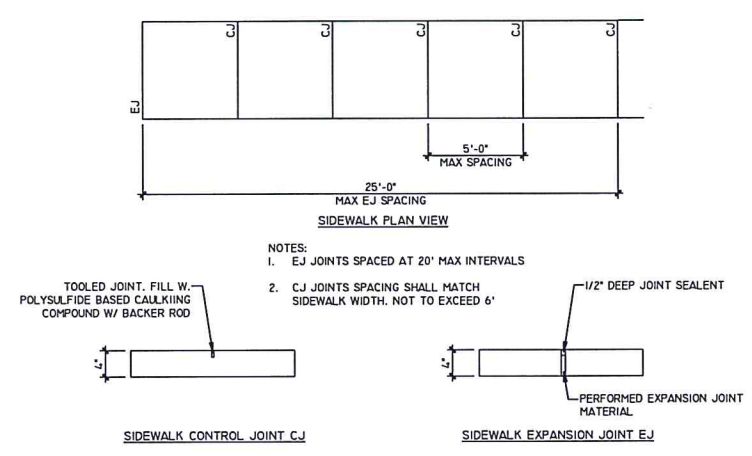
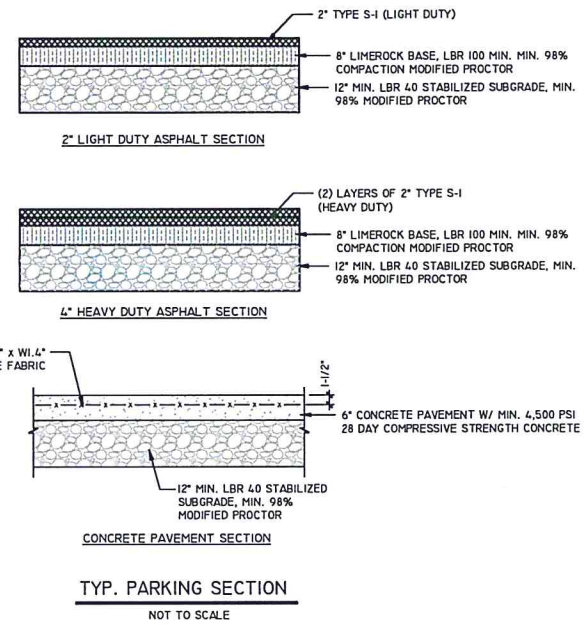

SIDEWALK CONTROL DETAILS
NOT TO SCALE



- NOTES:**
1. PROVIDE PAVEMENT SYMBOL IN ACCESSIBLE PARKING SPACES. THE SYMBOL SHALL BE WHITE IN COLOR PER ADA STANDARDS.
 2. BLUE MARKINGS SHALL BE SHADE 15180 PER FEDERAL STANDARD 5959.
 3. SLOPES NO GREATER THAN 1:8 (2.08%) SHALL BE PERMITTED IN ALL DIRECTIONS FOR BOTH THE ACCESSIBLE PARKING SPACE AND ACCESSIBLE PARKING ACCESS AISLE.
 4. ALL RAMPS, SIDEWALK CURB RAMPS AND ACCESSIBLE ROUTES SHALL BE ADA COMPLIANT.
 5. WIDTH MEASUREMENTS OF PARKING SPACES AND ACCESS AISLES SHALL BE MADE FROM THE CENTERLINE OF THE WHITE PAVEMENT MARKINGS. HOWEVER, WHEN PARKING SPACES OR ACCESS AISLES ARE ADJACENT TO A CURB OR EDGE OF PAVEMENT AND NOT ADJACENT TO ANOTHER PARKING SPACE OR ACCESS AISLE; THEN THE WIDTH MEASUREMENTS MAY INCLUDE THE FULL WIDTH OF THE LAST PAVEMENT MARKING.
 6. ALL ACCESSIBLE ELEMENTS SHALL BE COMPLIANT WITH THE DEPARTMENT OF JUSTICE 2010 ADA STANDARDS FOR ACCESSIBLE DESIGN AND THE FLORIDA BUILDING CODE SIXTH EDITION FOR "ACCESSIBILITY".
 7. ALL PARKING PAVEMENT MARKINGS SHALL BE 4" REFLECTORIZED PAINT MEETING FDOT/BCTD STANDARDS.

HANDICAP PARKING DETAIL
NOT TO SCALE

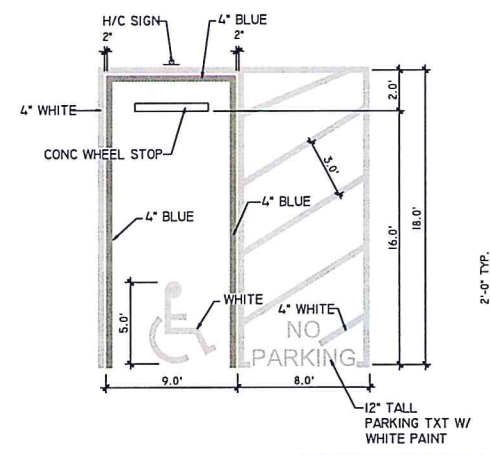

CORD. ARROW STRIPPING DETAILS WITH MDOT APPROVED DETAILS IN APPROVED PERMIT.

PARKING LOT STRIPING DETAILS
NOT TO SCALE

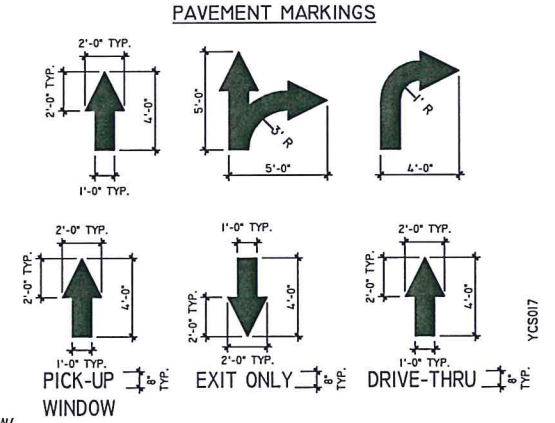

ALL PAVEMENT MARKINGS TO BE WHITE PAVEMENT PAINT, UNLESS STATED OTHERWISE.

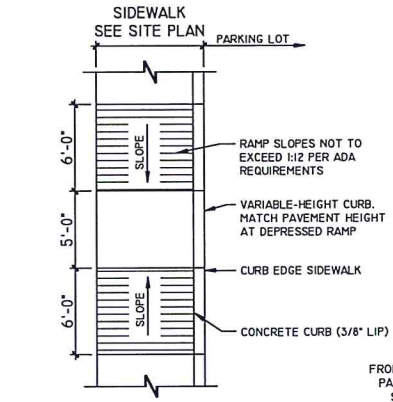

CONC. RAMP DETAIL
NOT TO SCALE

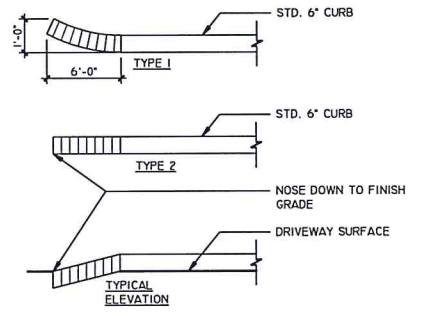

CONCRETE CURB DETAIL
NOT TO SCALE

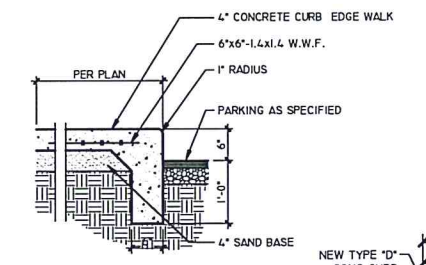

CONCRETE SIDEWALK DETAIL
NOT TO SCALE

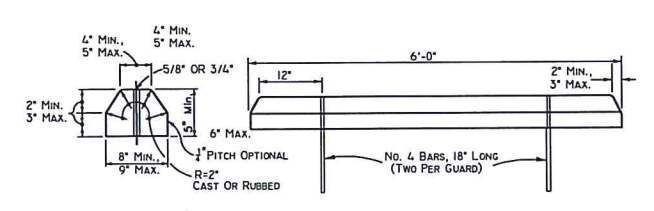

WHEEL STOP DETAIL
NOT TO SCALE

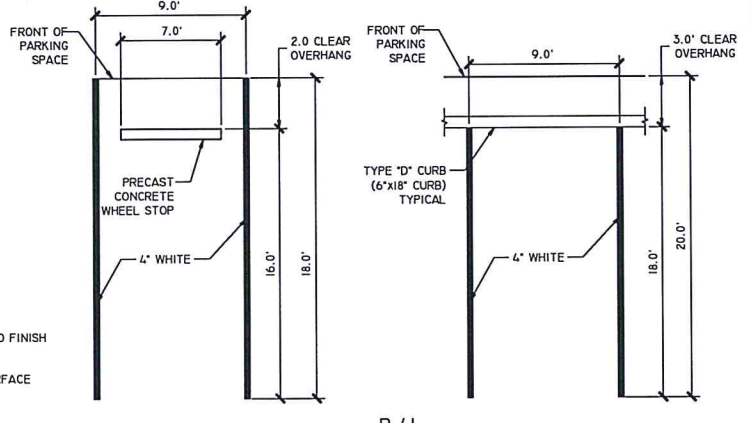

STANDARD PARKING DETAIL
NOT TO SCALE

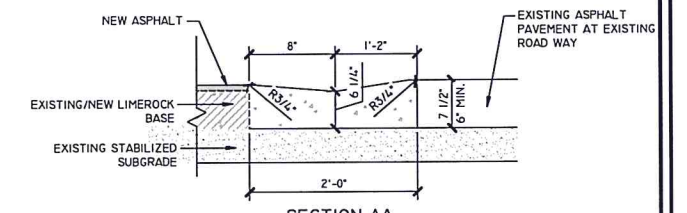

SECTION AA "VALLEY CURB"

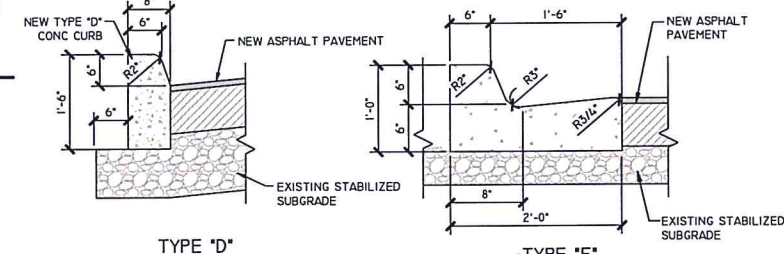

TYPE "D"

EXECUTIVE DIRECTOR APPROVAL

3-29-24 *A. Che*
Date By

CURB RAMP DETAIL.JPG

CONC. RAMP DETAIL
NOT TO SCALE

PAVING JOINTS.JPG

TYP. TYP. PARKING SECTION
NOT TO SCALE

ARCHITECTURE
ENGINEERING
LIS
LAND INVESTMENT SERVICES, LLC
CANTO, CALIFORNIA 92521
2672 West State Road 428
Pomona, CA 92465
Phone: (951) 244-9419
Facsimile: (951) 244-9418
21430 Palm Beach Blvd
Ave., FL 33050
Pompano Beach, FL 33062
Facsimile: (305) 883-8828

ADAM J. BARNEY
LAREGNO: 33092

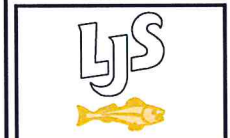

8928 JEWELLA AVE,
SHREVEPORT,
LOUISIANA 71118

REVISION		
No.	DATE	DESCRIPTION

DWG DATE: XX-XX-XXXX
DRAWN BY: CB / JC
PROJECT NO.: 2023-050
DWG TITLE:

TYPICAL DETAILS

SHEET No.
C-1.1

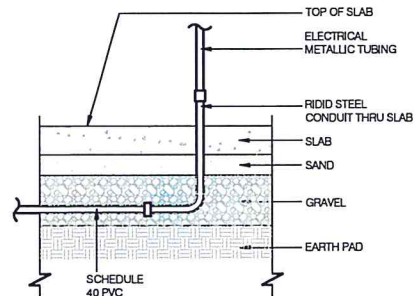

NOTE: GREEN GROUND WIRE REQUIRED IN ALL CONDUITS, SIZED PER N.E.C. REQUIREMENTS.

UNDER SLAB CONDUIT
NOT TO SCALE

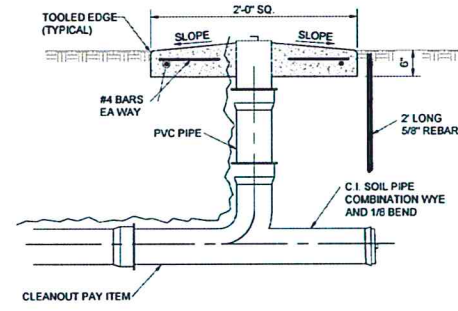

STANDARD CLEANOUT DETAIL
NOT TO SCALE

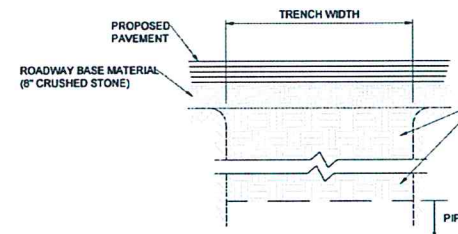

FINAL BACKFILL AT ROADWAY CROSSINGS
NOT TO SCALE

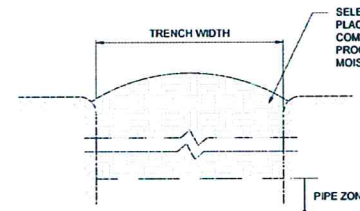

FINAL BACKFILL AT UNIMPROVED SURFACE
NOT TO SCALE

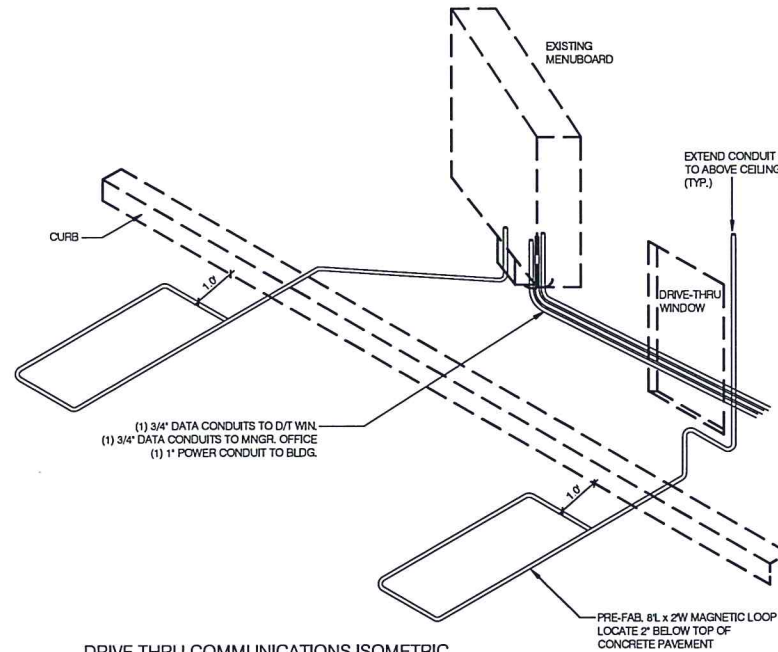

DRIVE THRU COMMUNICATIONS ISOMETRIC
NOT TO SCALE

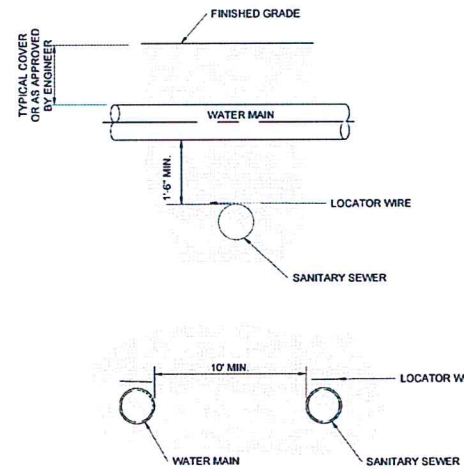

MINIMUM WATER/SEWER LINE SEPARATION
NOT TO SCALE

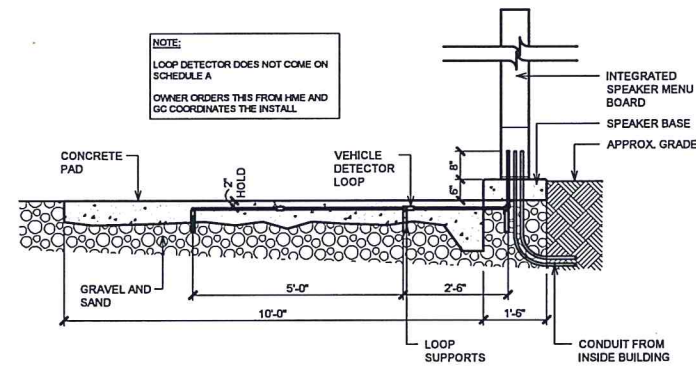

VEHICLE DETECTOR LOOP SECTION
NOT TO SCALE

NOTE: WHEN EXISTING CONDITIONS ARE UNSUITABLE FOR STANDARD BEDDING, CONTRACTOR SHALL NOTIFY ENGINEER. ENGINEER MAY PROVIDE CONTRACTOR WITH ANOTHER SUITABLE BEDDING DETAIL SPECIFIC TO EXISTING CONDITIONS.

4" MIN. (PIPES 24" DIA. AND SMALLER)
8" MIN. (PIPES 27" DIA. AND LARGER)

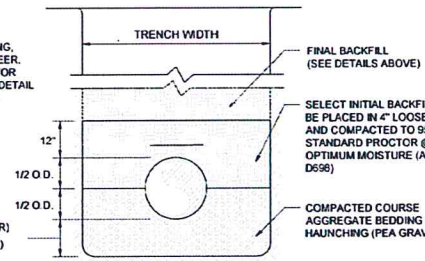

STANDARD BEDDING GRAVITY SEWER LESS THAN 24\"/>

SIZE OF PIPE	TRENCH WIDTH
4"	1'-10"
6"	2'-0"
8"	2'-2"
10"	2'-4"
12"	2'-6"
15"	2'-8"
18"	3'-0"
24"	3'-5"
30"	4'-0"

BEDDING & BACKFILL MATERIALS:

SELECT FINAL BACKFILL: ON-SITE MATERIALS USED FOR BACKFILLING SHALL BE FREE OF REFUSE, Boulders, ASH, CINDER, ROCKS/STONES, AND UNSUITABLE ORGANIC MATERIAL OR OTHER MATERIAL WHICH IN THE OPINION OF THE ENGINEER IS UNSUITABLE. BACKFILL MATERIAL SHALL BE COMPACTED TO 95% STANDARD PROCTOR DENSITY. ENGINEER SHALL OBSERVE ALL ON-SITE MATERIALS THAT ARE TO BE USED FOR BACKFILLING PRIOR TO THEIR USE.

INITIAL BACKFILL: AGGREGATE BEDDING, HAUNCHING AND BACKFILL SHALL HAVE A UNIFIED SOIL CLASSIFICATION OF GW (GRAVEL-SAND MIXTURES AND WELL GRADED GRAVEL), GP (GRAVEL-SAND MIXTURES AND POORLY GRADED GRAVELS), SW (GRAVELLY SANDS AND WELL GRADED SANDS), SP (GRAVELLY SANDS AND POORLY GRADED SANDS). PEA GRAVEL IS ALSO ACCEPTABLE.

COURSE AGGREGATE: COURSE AGGREGATE SHALL CONSIST OF CRUSHED OR ROUND GRAVEL AND SHALL BE CLEAN AND FREE OF CLAY AND ORGANIC MATERIALS. THE AGGREGATE SHALL HAVE THE FOLLOWING GRADATION:

SIEVE	% PASSING
3/4"	100%
1/2"	80-85%
3/8"	50-75%
#40	5-15%
#10	5% (Min.)

SELECT BORROW BACKFILL: BORROW BACKFILLING MATERIALS SHALL HAVE A UNIFIED SOIL CLASSIFICATION OF "CL" WITH A PLASTICITY INDEX RANGE OF 5-15 (SUBSTITUTIONS MAY BE USED WITH PRIOR ENGINEER APPROVAL ONLY).

AIR TEST TECHNIQUE:

THE AIR TEST TECHNIQUE SHALL CONSIST OF TESTING BETWEEN EVERY TWO CONSECUTIVE MANHOLES. THE TEST SECTION SHALL BE FLUGGED AT EACH END WITH ONE OF THE PLUGS TAPPED AND EQUIPPED FOR THE AIR INLET CONNECTION FOR FILLING THE LINE FROM THE AIR COMPRESSOR. THE AIR CONTROL EQUIPMENT SHALL INCLUDE THE PRESSURE GAUGE HAVING A PRESSURE RANGE FROM 0 TO 5 PSI. THE GAUGE SHALL HAVE MINIMUM DIVISIONS OF 0.1 PSI AND AN ACCURACY OF ± 0.04 PSI. THE AIR SHALL BE SUPPLIED TO THE TEST SECTION SLOWLY, FILLING THE PIPE LINE UNTIL A CONSTANT PRESSURE OF 3.5 PSI IS MAINTAINED. THE PRESSURE INSIDE THE MAIN SHALL NOT EXCEED 5.0 PSI. AFTER A CONSTANT PRESSURE OF 3.5 PSI HAS BEEN MAINTAINED FOR AT LEAST 5 MINUTES, THE AIR PRESSURE SHALL BE INCREASED TO 4.0 PSI AND SHUT OFF. AS THE PRESSURE FALLS, THE OFFICIAL TIMING WILL BE STARTED WHEN THE PRESSURE REACHES 3.5 PSI AND THE TIMING SHALL CONTINUE UNTIL THE LINE PRESSURE DROPS TO 2.5 PSI AT WHICH TIME THE STOP WATCH WILL BE STOPPED. IF THE TIME, IN MINUTES AND SECONDS, FOR THE AIR PRESSURE TO DROP FROM 3.5 PSI TO 2.5 PSI IS GREATER THAN THAT SHOWN IN THE FOLLOWING TABLE FOR THE DESIGNATED PIPE SIZE, THE TEST SECTION SHALL HAVE PASSED. HOWEVER, IF THE TIME IS LESS THAN THAT SHOWN, THE TEST SECTION WILL NOT BE ACCEPTED AND THE CONTRACTOR SHALL CORRECT THE DEFECTS IN THE SECTION UNTIL THE TEST PASSES.

IF THE PIPE TO BE TESTED IS SUBMERGED IN GROUND-WATER, THE BACK PRESSURE DUE TO GROUND SUBMERGENCE OVER THE END OF THE PROBE SHALL BE ADDED TO ALL GAUGE PRESSURES IN THE TEST.

PIPE DIAMETER	100'	200'	300'	400'	500'
4"	1:53	1:53	1:53	1:53	1:53
6"	2:49	2:49	2:49	2:49	3:18
8"	3:45	3:45	3:45	4:41	5:52
10"	4:43	4:43	5:39	7:20	9:10
12"	5:40	5:40	7:55	10:33	13:12
15"	7:05	8:14	12:22	16:29	20:37
18"	8:30	11:52	17:49	23:45	29:41
24"	11:20	21:07	31:40	42:14	52:47
30"	16:29	35:59	49:29	65:59	82:29

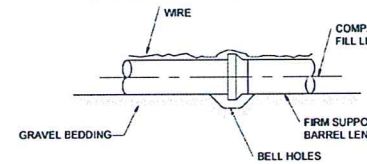

PROVIDE UNIFORM AND CONTINUOUS SUPPORT OF PIPE BARREL BETWEEN BELL OR COUPLING HOLES.

FOUNDATION BELL HOLE DETAIL
NOT TO SCALE

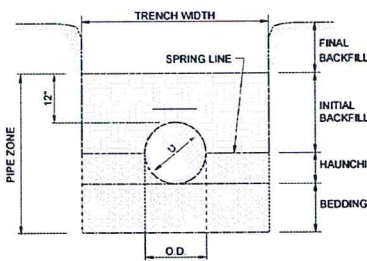

TRENCH CROSS SECTION TERMINOLOGY AND WIDTHS
NOT TO SCALE

EXECUTIVE DIRECTOR APPROVAL

By *Ar Al*
Date **3-29-24**

ARCHITECTURE ENGINEERING
LIS
LAND INVESTMENT SERVICES, LLC
CAN. REG. C05690 E.O.S. CERT. LP#00020466001
9579 Hwy. 604, Suite 100, OES
Suite 204, Orange, FL 32705
Phone: (321) 244-9402
Fax: (321) 244-9419
Fic: (28) 055-9244
Fic: (28) 055-9628

ADAM J. BARRY
LA REG. NO. 35092

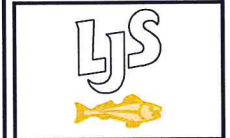

**8928 JEWELLA AVE,
SHREVEPORT,
LOUISIANA 71118**

REVISION		
No.	DATE	DESCRIPTION

DWG DATE: XX-XX-XXXX
DRAWN BY: CB / JC
PROJECT No.: 2023-050
DWG TITLE: TYPICAL DETAILS



Know what's below.
Call before you dig.

1 PYLON SIGN DETAIL (B9)
Scale: N.T.S.

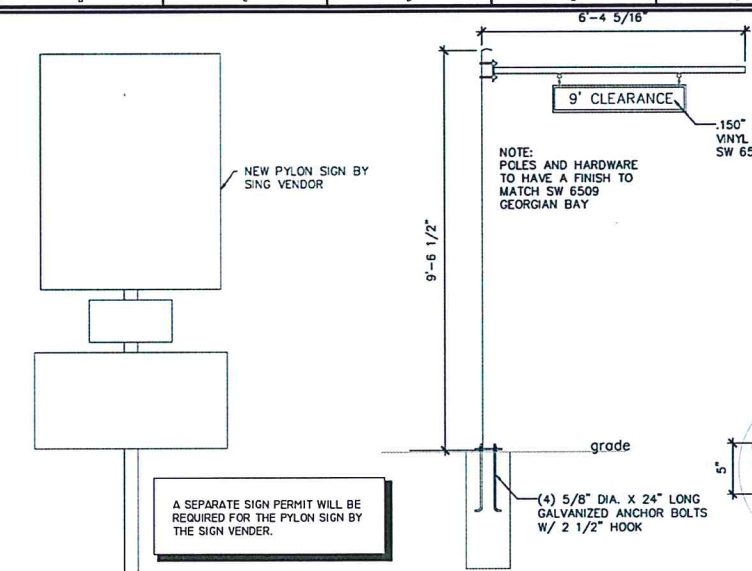

2 CLEARANCE BAR (H9)
Scale: N.T.S.

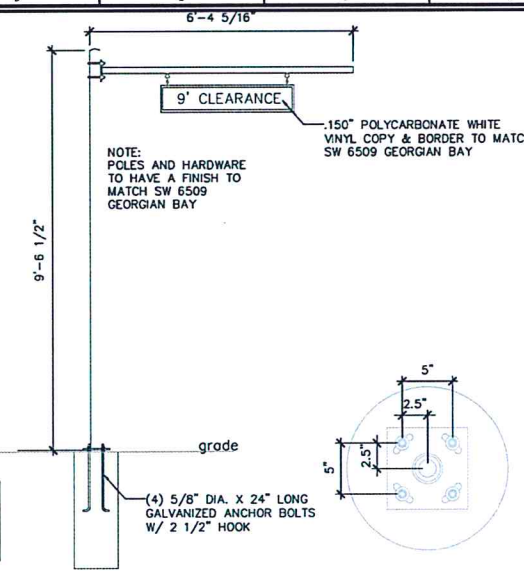

3 MENUBOARD PLAN - CURVED OPTION
Scale: 1" = 8'

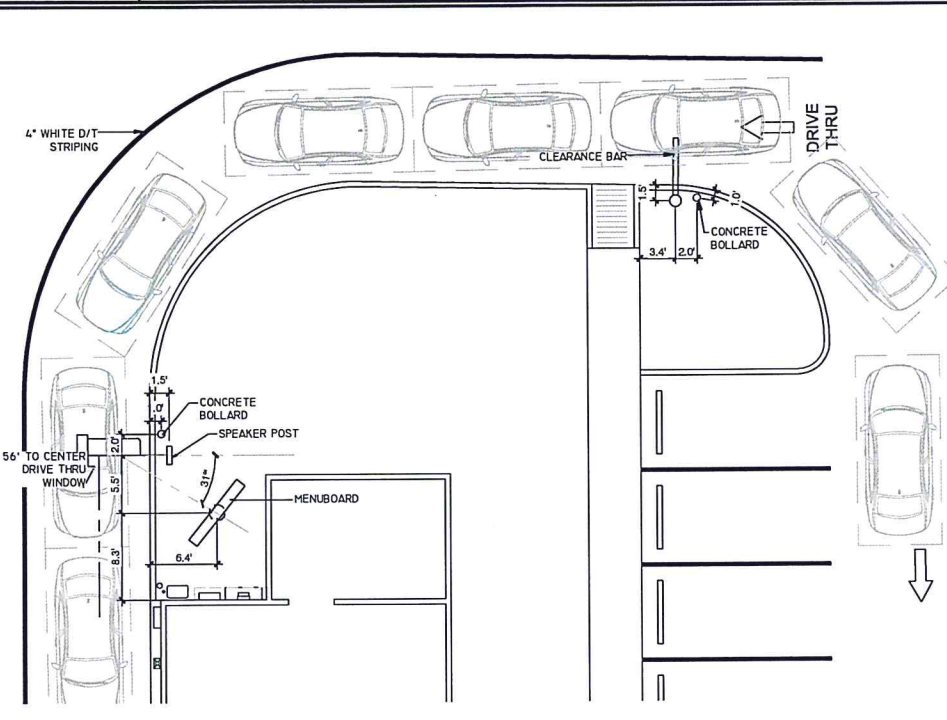

4 MENU BOARD DETAIL
Scale: N.T.S.

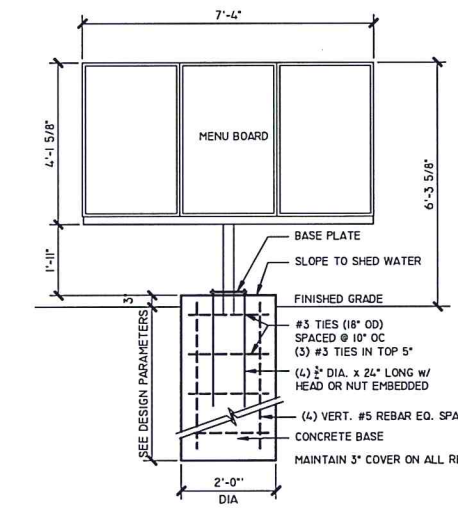

PERMITTING AND INSTALLATION BY OTHERS

CLASS 5 SOIL FOUNDATION REQUIREMENTS

DESIGN PARAMETERS
2020 INTERNATIONAL BUILDING CODE
ASCE 7-05 WIND SPEED DATA:
• BASIC WIND SPEED = 90 MPH; 3 SEC GUST
4'-6" FOUNDATION DEPTH
• BASIC WIND SPEED = 120 MPH; 3 SEC GUST
5'-6" FOUNDATION DEPTH
• BASIC WIND SPEED = 150+ MPH; 3 SEC GUST
6'-9" FOUNDATION DEPTH
• WIND IMPORTANCE FACTOR 1.0
• WIND EXPOSURE C
• INTERNAL PRESSURE COEF. N/A
• COMPONENT AND CLADDING N/A

ASCE 7-10 SPEC RATED APPX 28% HIGHER OVER
ASCE 7-05 SPEC

MATERIALS
GRADE F154 GR 36 ANCHOR BOLTS
GRADE 615 60 KSI REBAR
3000 PSI CONCRETE @ 28 DAYS
CLASS 5 SOIL:
1500 PSF SOIL BEARING
100 PSF/LF SOIL LATERAL BEARING
UNDISTURBED SOIL

FRANCHISEE PREFERENCE TO
BUILD FOR +150 MPH WINDSPEED
(AS SHOWN)

5 CONCRETE BOLLARD (H4)
Scale: N.T.S.

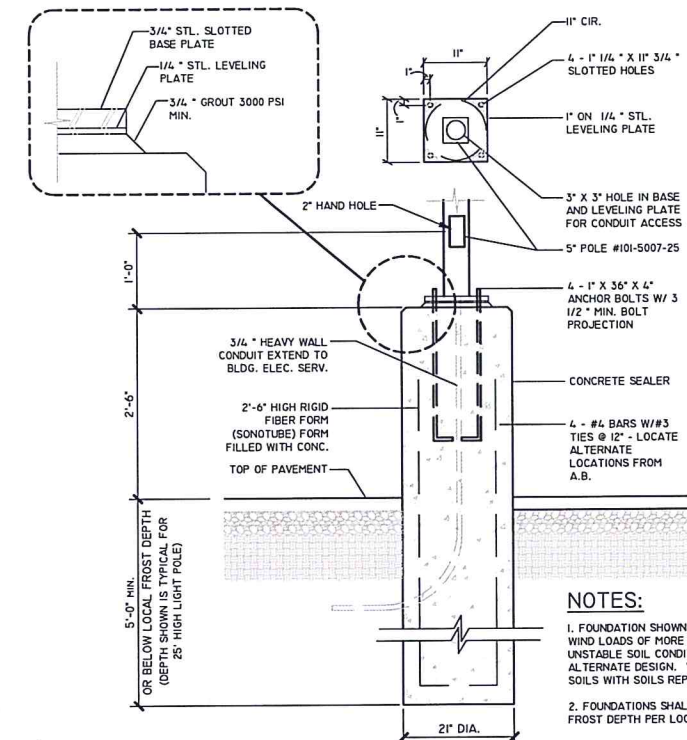
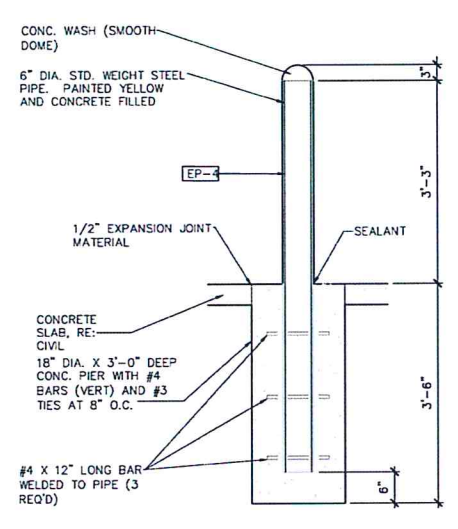

6 LIGHT POLE FOUNDATION DETAIL
Scale: N.T.S.

5 MENU BOARD FOUNDATION DETAIL
Scale: N.T.S.

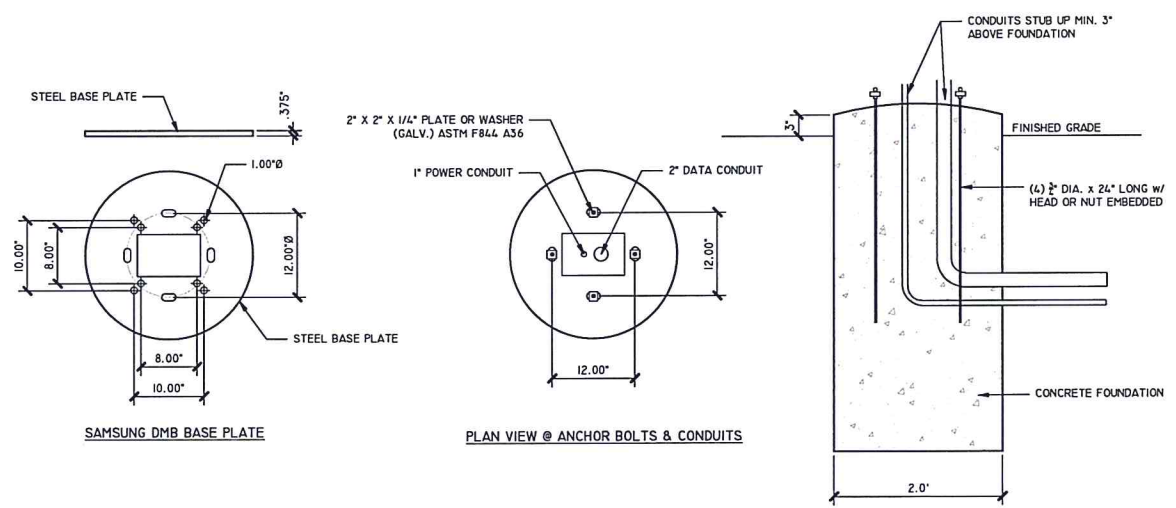

6 CONCRETE BOLLARD DETAIL
Scale: N.T.S.

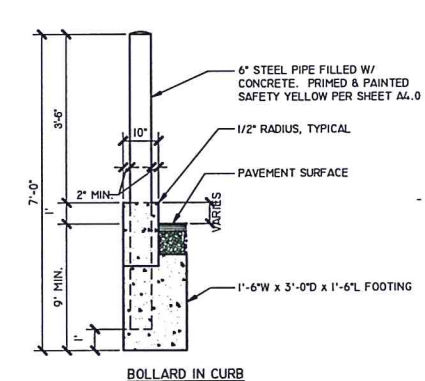

EXECUTIVE DIRECTOR APPROVAL

3-28-24 Date By *AA*

Know what's below. Call before you dig.



ARCHITECTURE
ENGINEERING
LIS
LAND INVESTMENT SERVICES, LLC
CA NO. C05890 SOS CERT. LF0002666001
2573 West Chas. Road, 2nd Fl.
Suite 204, Orange, FL 32765
Phone: (321) 244-0402
Facsimile: (321) 244-9419
21450 Palm Beach Blvd
Palm Beach Gardens, FL 33418
Phone: (335) 853-9244
Facsimile: (335) 853-9828

ADAM J. BARNIEY
LA REG. NO. 35092

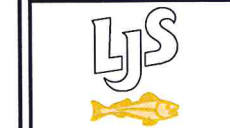

8928 JEWELLA AVE,
SHREVEPORT,
LOUISIANA 71118

REVISION		
No.	DATE	DESCRIPTION

DWG DATE: XX-XX-XXXX
DRAWN BY: CB / JC
PROJECT No.: 2023-050
DWG TITLE:

TYPICAL DETAILS

SHEET No.
C-1.3

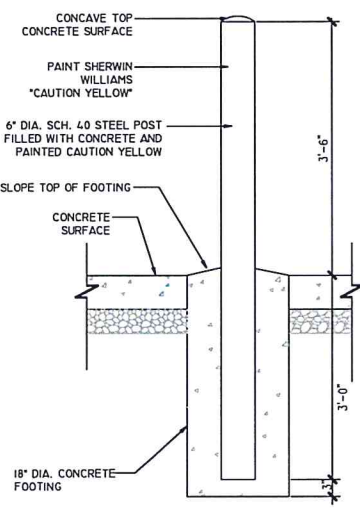

8 BOLLARD DETAIL SCALE: N.T.S.

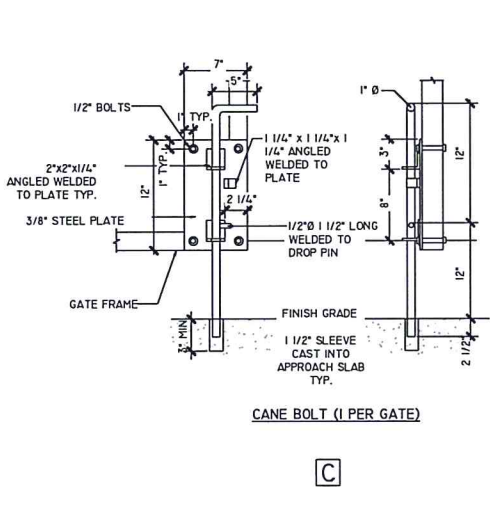

4 GATE DETAILS & NOTES SCALE: N.T.S.

GATE HARDWARE: ALL HARDWARE AND ACCESSORIES SHALL BE HOT DIPPED GALVANIZED.

GATE STOP: MUSHROOM TYPE OR FLUSH PLATE WITH ANCHORS SET IN CONCRETE TO ENGAGE THE CENTER DROP ROD OR PLUNGER BAR.

GATE NOTES: (4) EQUAL WIDE x 7'-6" HIGH MTL. GATES, TYPE 'B' 1 1/2" DECKING, 14GA. W/ T.S. 1 X 1875 BAR CROSS BRACING WELD AND GRIND SMOOTH ALL CONNECTIONS, TYP. PRIME AND PAINT ALL STEEL COMPONENTS.

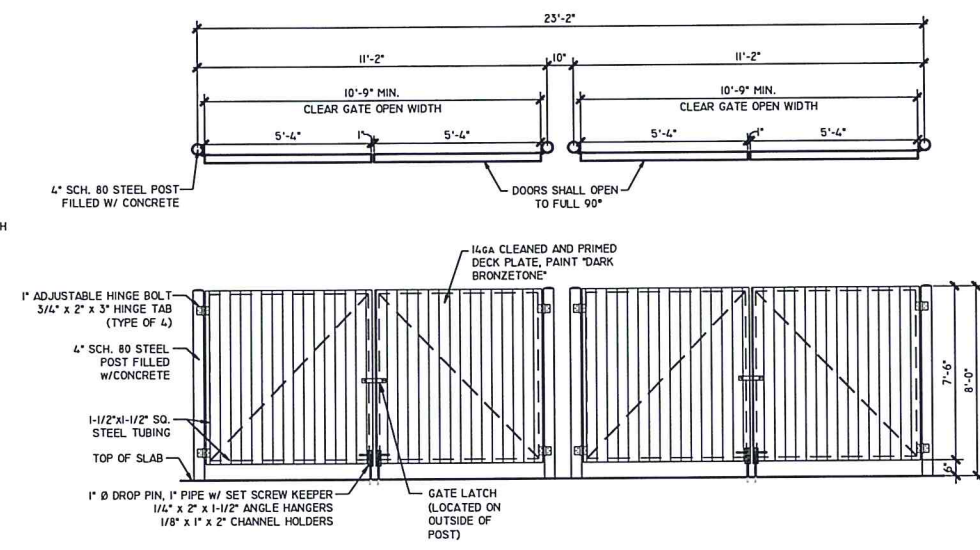

1 GATE PLAN AND FRONT ELEVATION SCALE: N.T.S.

EXECUTIVE DIRECTOR APPROVAL

Date: 3-28-24 By: [Signature]

- NOTES:**
- LOCATION SHALL BE APPROVED BY THE PUBLIC WORKS DEPARTMENT.
 - AREAS SHALL BE ACCESSIBLE FOR DELIVERY AND COLLECTION.
 - GATES SHALL BE CORRUGATED METAL DOORS AND MUST BE APPROVED BY PUBLIC WORKS DEPARTMENT PRIOR TO INSTALLATION.
 - GATE LATCHES SHALL BE OF THE PLUNGER BAR TYPE OR EQUIVALENT AS APPROVED BY THE PUBLIC WORKS DEPARTMENT.
 - SEE ATTACHED SPECIFICATIONS, NOTES AND PROCEDURES.

- TRASH ENCLOSURE DETAIL MATERIAL SPECIFICATIONS:**
- CONCRETE BLOCK: 8" MINIMUM IN SIZE. ASTM C90.
 - REINFORCING STEEL: ASTM 615, GRADE 40.
 - ACCEPTABLE SOIL TYPES:
 - MIN. ALLOWABLE BEARING: 1000 LBS/SQ. FT
 - MIN. LATERAL BEARING: 100 LBS/SQ. FT./FT.
 - MAX EXPANSION INDEX: 20
 - CONCRETE: 2000 LBS/SQ. IN. IN 28 DAYS.
 - MORTAR: 1:1/2:3 (PORTLAND CEMENT: HYDRATED LIME OR LIME PUTTY: SAND, BY VOLUME). MIXED TO PLASTIC CONSISTENCY. REFER TO UBC TABLE 24-A FOR OTHER TYPES OF CEMENT.
 - GROUT: 1:1/2:3 (PORTLAND CEMENT: HYDRATED LIME OR LIME PUTTY: SAND BY VOLUME) MIX TO FLOW WITHOUT SEGREGATION. GROUT MAY CONTAIN 2 PARTS PEA GRAVEL (3/8" MAX. SIZE). MINIMUM COMPRESSIVE STRENGTH: 2000 LBS/SQ. IN. REFER TO UBC TABLE 24-B FOR OTHER TYPES OF CEMENT.

- GENERAL NOTES:**
- THIS DESIGN IS FOR AVERAGE CONDITIONS AND MAY NOT BE SUITABLE FOR ALL CASES. IT IS RECOMMENDED THAT A LICENSED CIVIL OR STRUCTURAL ENGINEER BE CONSULTED.
 - FOOTINGS SHALL BE IN NATURAL SOIL OR CERTIFIED FILL.
 - BLOCKS TO BE STAGGERED (RUNNING BOND).
 - ALL CELLS CONTAINING REINFORCING STEEL SHALL BE GROUTED.
 - APPROVED GROUT STOPS ARE REQUIRED BELOW HORIZONTAL STEEL IN PARTIALLY GROUTED WALLS. BAGS, NEWSPAPERS, ETC. ARE NOT APPROVED GROUT STOPS.
 - INITIAL BED JOINT SHALL BE 1/4" MIN. 1" MAX. SUBSEQUENT BED JOINTS SHALL BE 1/4" MIN., 5/8" MAX.
 - VERTICAL CONTINUITY OF CELLS SHALL BE UNOBSTRUCTED. MORTAR PROJECTIONS SHALL NOT EXCEED 1/2" FOR 6" AND LARGER BLOCK. MORTAR DROPPINGS OR OTHER FOREIGN MATTER ARE NOT PERMITTED IN CELLS AND MUST BE REMOVED.
 - EXPANSION JOINTS REQUIRED AT 60'-0" MAX. INTERVALS.
 - REQUIRED BAR LAPS:
 - VERTICAL STEEL: 30 BAR DIAMETERS.
 - HORIZONTAL STEEL: 40 BAR DIAMETERS.
 - WIRE JOINT REINFORCEMENT IN THE MORTARED BED JOINT: 75 WIRE DIAMETERS OR IN ALTERNATE BED JOINTS OF RUNNING BOND, 5/8 DIAMETERS PLUS TWICE THE BED JOINT SPACING.
 - WHERE HORIZONTAL WIRE JOINT REINFORCEMENT IS REQUIRED OR UTILIZED, IT SHALL BE EQUIVALENT TO TWO 3/16" DIAMETER BARS CONNECTED AT 16" INTERVALS BY NO. 9 GAUGE WELDED WIRE.
 - FOR PIPES AND CONDUIT EMBEDDED IN MASONRY, REFER TO SEC. 24-07(C), UBC.
 - 3" MIN. COVER REQUIRED FOR REINFORCEMENT IN CONCRETE WHICH IS CAST AGAINST EARTH.
- INSPECTION PROCEDURES:**
- FOUNDATION: AFTER TRENCHES ARE DUG, STEEL IS TIED IN PLACE AND BEFORE ANY CONCRETE IS POURED.
 - PRE-GROUT: AFTER ALL BLOCKS (EXCEPT CAP) ARE IN PLACE, VERTICAL AND HORIZONTAL STEEL IS IN PLACE, GROUT STOPS (FOR PARTIALLY CROUTED MASONRY) ARE IN PLACE AND PRIOR TO GROUTING.
 - FINAL: AFTER GROUT IS IN PLACE AND PRIOR TO PLACEMENT OF CAP.

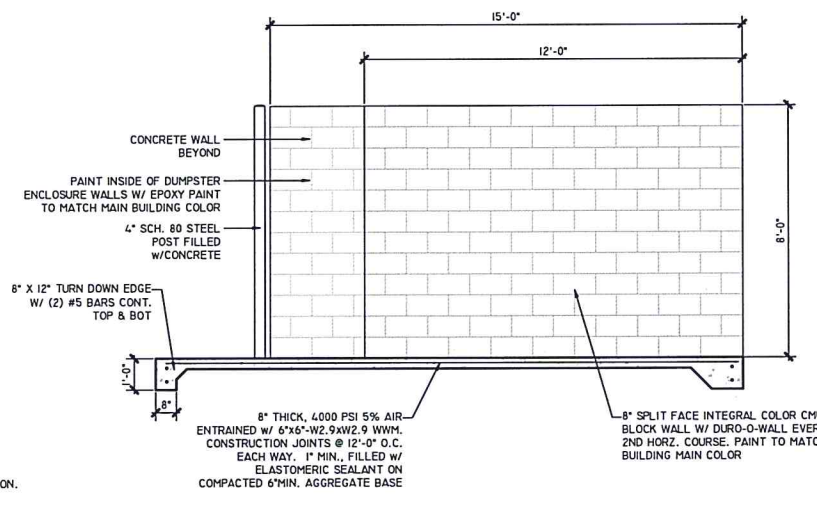

5 DUMPSTER PAD SECTION SCALE: N.T.S.

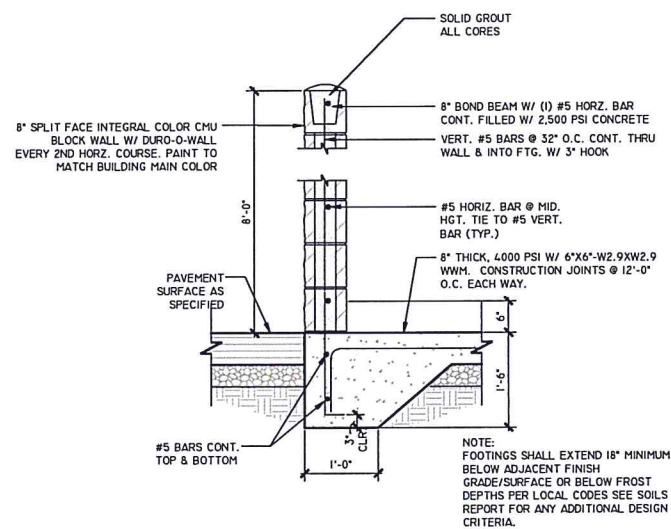

6 TYP. SIDE ELEVATION SCALE: N.T.S.

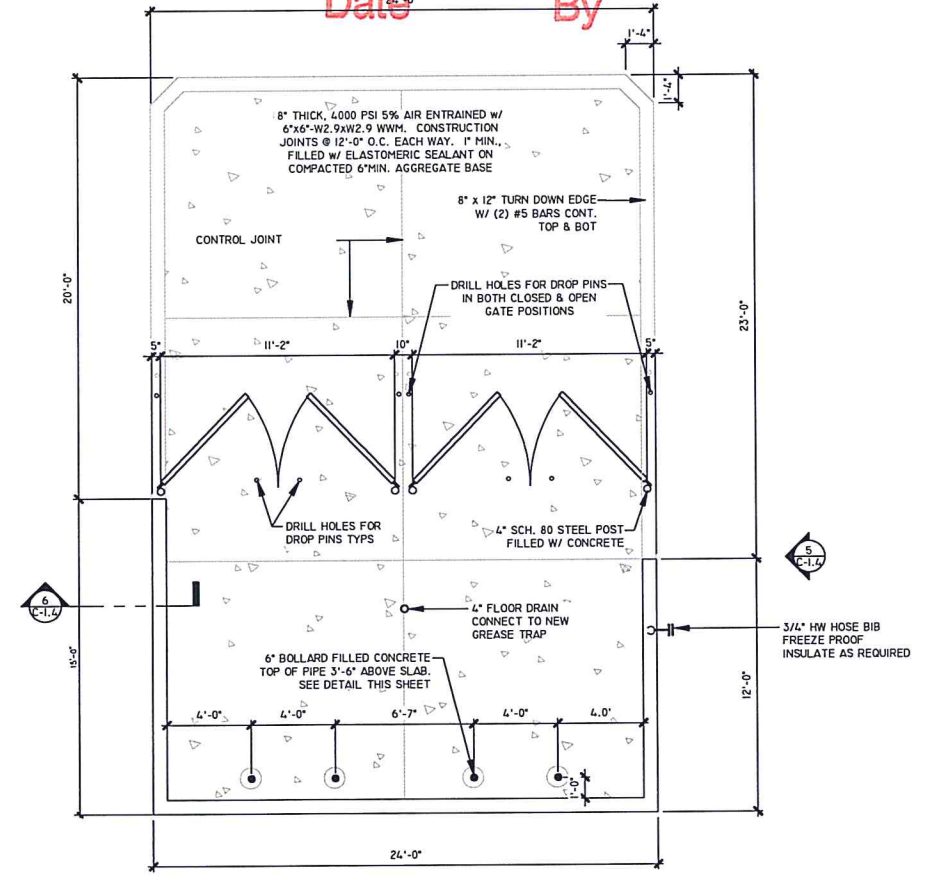

2 ENLARGED DUMPSTER PLAN SCALE: N.T.S.

LIS ARCHITECTURE ENGINEERING

LAND INVESTMENT SERVICES, LLC
 CA NO: 026860 EOG CERT# LP00026465001
 2577 West 64th Ave. Suite 102
 Springdale, FL 32756
 Phone: (321) 244-9002
 Facsimile: (321) 244-9419

21450 Palm Beach Blvd
 Suite 100
 Palm Beach Gardens, FL 33418
 Phone: (561) 953-3944
 Facsimile: (561) 953-3928

ADAM J. BARNEY
 LA REG NO. 35092

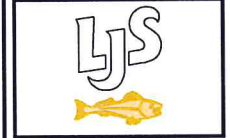

8928 JEWELLA AVE,
 SHREVEPORT,
 LOUISIANA 71118

REVISION		
No.	DATE	DESCRIPTION

DWG DATE: XX-XX-XXXX
 DRAWN BY: CB / JC
 PROJECT NO.: 2023-050
 DWG TITLE:

TYPICAL DETAILS

SHEET No.
C-1.4

LEGEND

- ▲ Found Railroad Spike
- Found 5/8" Iron Rod (Unless Noted)
- Concrete Filled Bollard
- ♿ Handicap Parking
- Ⓣ Telephone Pedestal
- Ⓢ Cable TV Pedestal
- Ⓜ Electric Meter
- Ⓜ Gas Meter
- Ⓢ Sign
- Ⓢ Sewer Cleanout
- Ⓢ Power Pole
- Ⓢ Light Pole
- Ⓢ Trees/Bushes

× 320.42' Spot Elevation

- SERVITUDE/EASEMENT
- RIGHT OF WAY
- BOUNDARY LINE
- CENTERLINE
- FENCE LINE
- OVERHEAD LINES
- Landscaping

- REFERENCE SURVEYS:**
- SOUTH PARK MALL, A COMMERCIAL SUBDIVISION BY JOHN L. NORMAND JR. RLS NO. 253, DATED DECEMBER 1975 (BOOK 1500, PAGE 269-271).
 - SUMMER GROVE AT SOUTH PARK SUBDIVISION, UNIT 2 BY JAMES D. MOHR. PLS NO. 2714, DATED AUGUST 2007 (INSTRUMENT NO. 2119015).
 - SUMMER GROVE AT SOUTH PARK SUBDIVISION BY JAMES D. MOHR. PLS NO. 2714, DATED FEBRUARY 2005 (INSTRUMENT NO. 1961270).
 - SOUTH PARK MALL, UNIT 2 BY JOHNNIE CRAIG. PLS NO. 4587, DATED OCTOBER 1995 (BOOK 2300, PAGE 65).

NOTES:

BASIS OF BEARINGS:
RELATIVE TO GRID BEARINGS OF LOUISIANA COORDINATE SYSTEM OF 1983 - NORTH ZONE, AS OBTAINED BY GPS OBSERVATION (REFERENCE FRAME: NAD_83(2011)(EPOCH:2010.000)).

VERTICAL DATUM: THE VERTICAL DATUM IS NAVD88 COMPUTED USING GEOID18 BASED ON GPS OBSERVATION AND OPUS POST PROCESSING.

THIS PLAT DOES NOT REPRESENT A GUARANTEE OF TITLE. I DID NOT CONDUCT EXTENSIVE TITLE RESEARCH. NO COPIES OF SERVITUDES WERE PROVIDED AND NOT NECESSARILY ALL ARE SHOWN HEREON.

LOUISIANA ONE CALL NOTE:
A ONE CALL WAS SUBMITTED TO LOUISIANA ONE CALL 811 ON 05/2023. NOT ALL UTILITY COMPANIES RESPONDED. THE UTILITY LOCATIONS SHOWN HEREON ARE APPROXIMATE AND SHOULD BE VERIFIED IN THE FIELD.

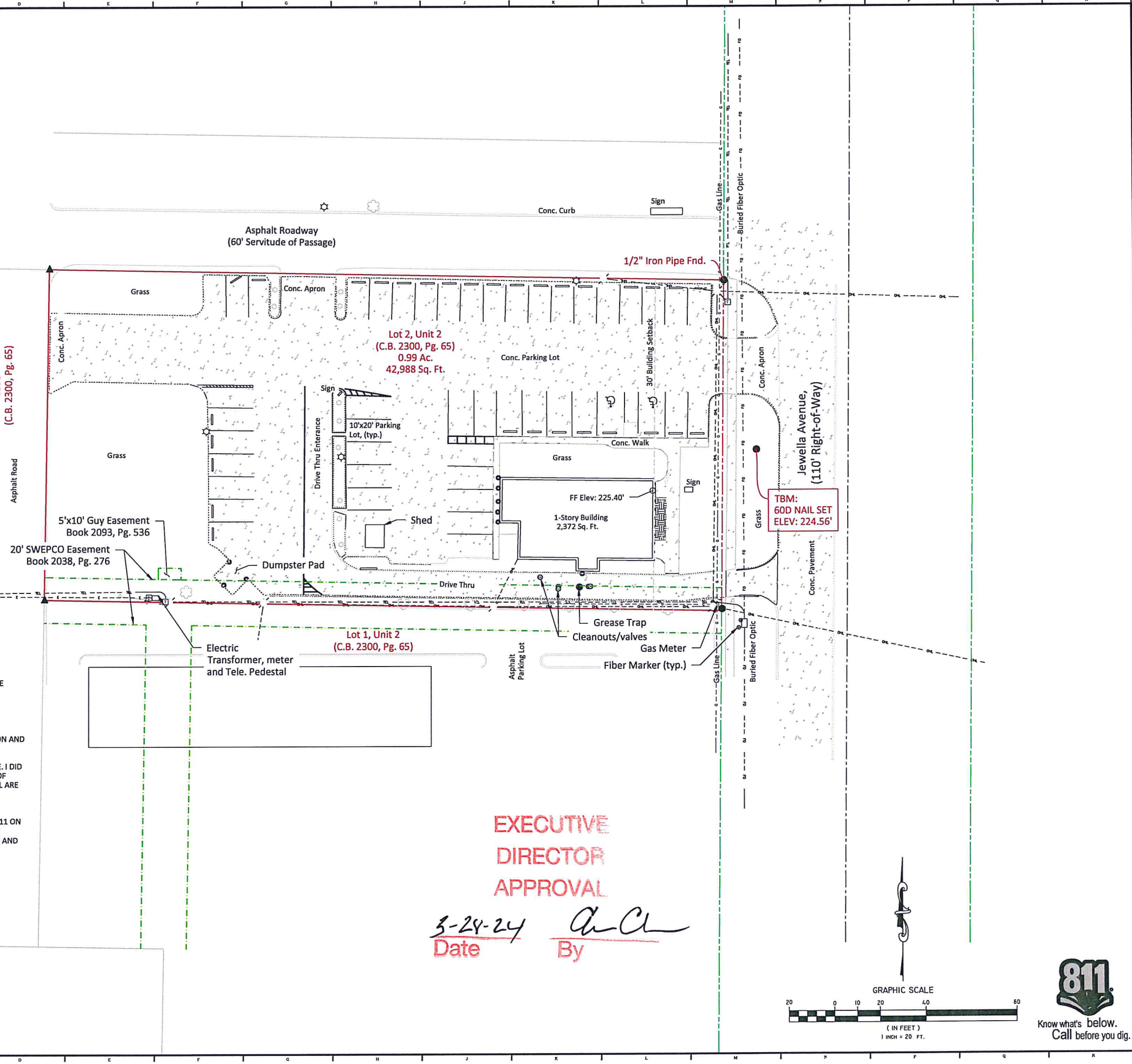

EXECUTIVE DIRECTOR APPROVAL

3-24-24
Date By

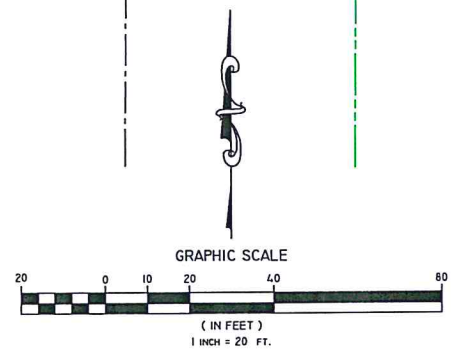

ARCHITECTURE ENGINEERING

LIS

Louisiana Surveying & Engineering, LLC
 CA No. 05680 EGS CERT # LP0000666001
 2579 West Side Road #200
 Shreveport, LA 71205
 Phone: (504) 833-3244
 Facsimile: (504) 244-9419

ADAM J. BARNEY
 LA REG. NO. 33092

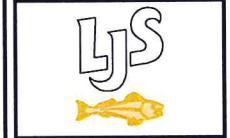

**8928 JEWELLA AVE,
 SHREVEPORT,
 LOUISIANA 71118**

REVISION		
No.	DATE	DESCRIPTION

DWG DATE: XX-XX-XXXX
 DRAWN BY: CB / JC
 PROJECT No.: 2023-050
 DWG TITLE:

EXISTING PLAN

SHEET No.
C-2.0

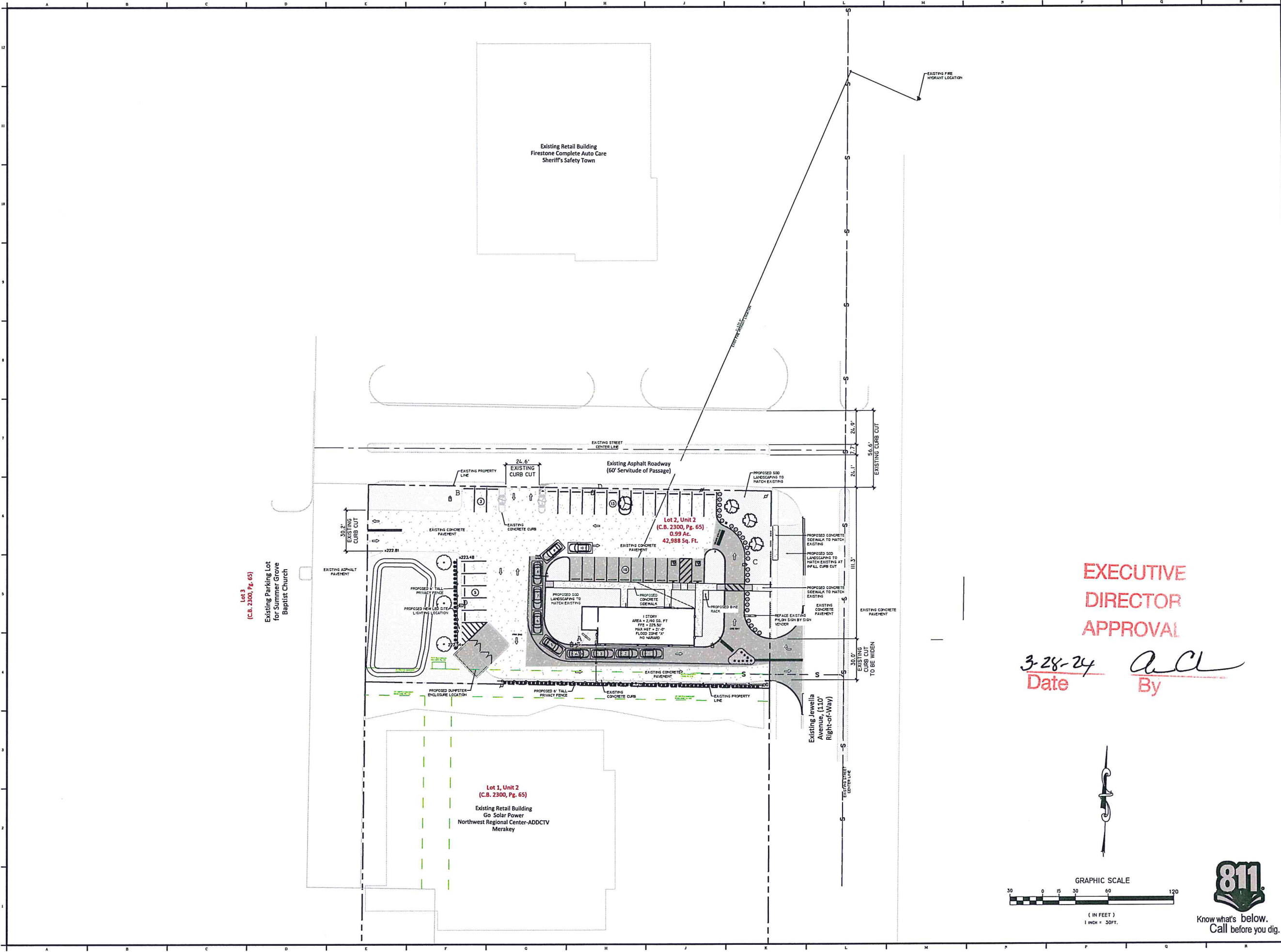

Lot 3
(C.B. 2300, Pg. 65)
Existing Parking Lot
for Summer Grove
Baptist Church

Lot 1, Unit 2
(C.B. 2300, Pg. 65)
Existing Retail Building
Go Solar Power
Northwest Regional Center-ADDCTV
Merakey

Lot 2, Unit 2
(C.B. 2300, Pg. 65)
0.99 Ac.
42,988 Sq. Ft.

**EXECUTIVE
DIRECTOR
APPROVAL**

3-28-24
Date

ACL
By

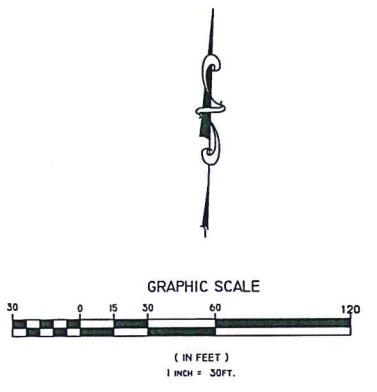

LIS ARCHITECTURE ENGINEERING

LAND INVESTMENT CONSULTANTS, LLC
 CA No. 008880 | BLS CERT# 1P0000946001
 2672 West Blue Road #26
 Jacksonville, FL 32209
 Phone: (321) 244-9402
 Facsimile: (321) 244-9419

21430 Palm Beach Blvd
 Ana, FL 33500
 Phone: (813) 244-9402
 Facsimile: (813) 244-9419

ADAM J. BARNEY
 LAREG NO. 33092

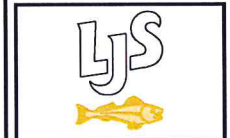

8928 JEWELLA AVE,
 SHREVEPORT,
 LOUISIANA 71118

REVISION		
No.	DATE	DESCRIPTION

DWG DATE: XX-XX-XXXX
 DRAWN BY: CB / JC
 PROJECT No.: 2023-050
 DWG TITLE:

OVERALL DESIGN
 PLAN

SHEET No.
C-3.0

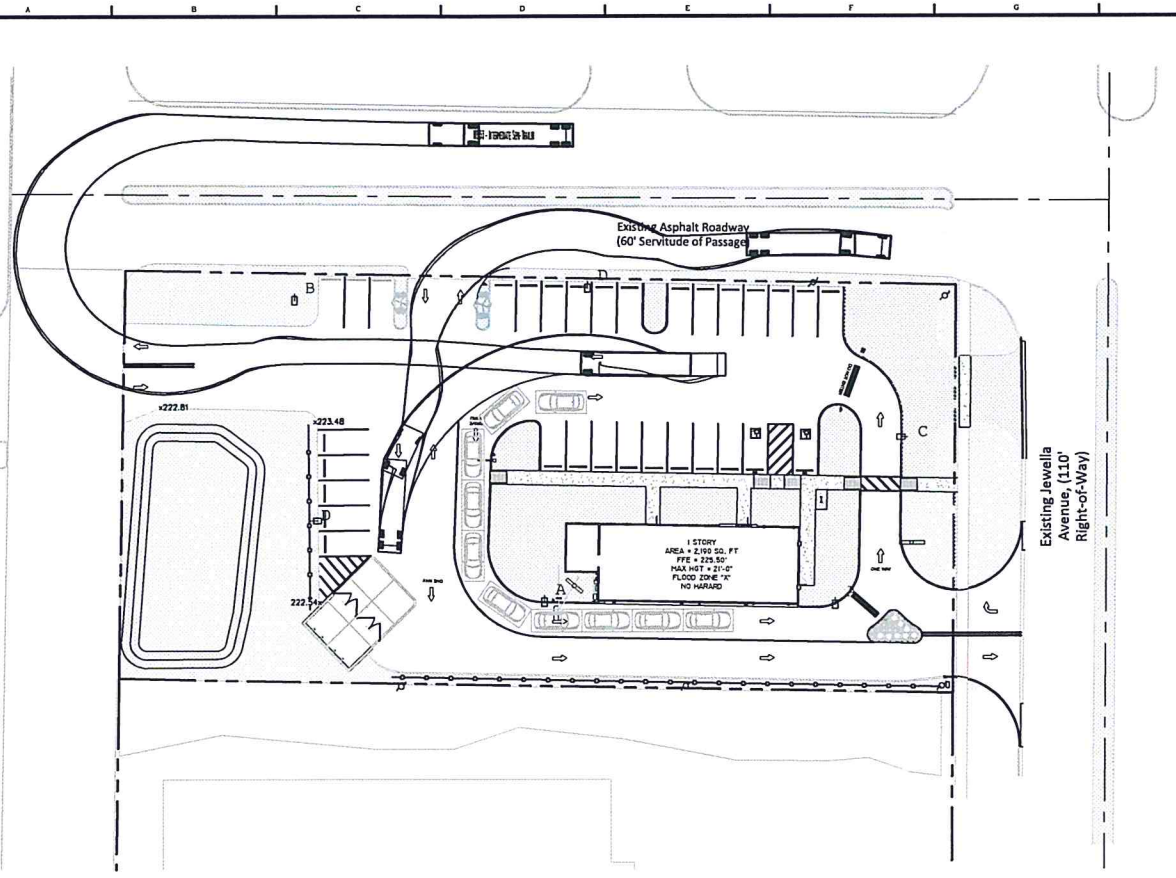

DELIVERY TRUCK ROUTE
SCALE: 30' = 1'

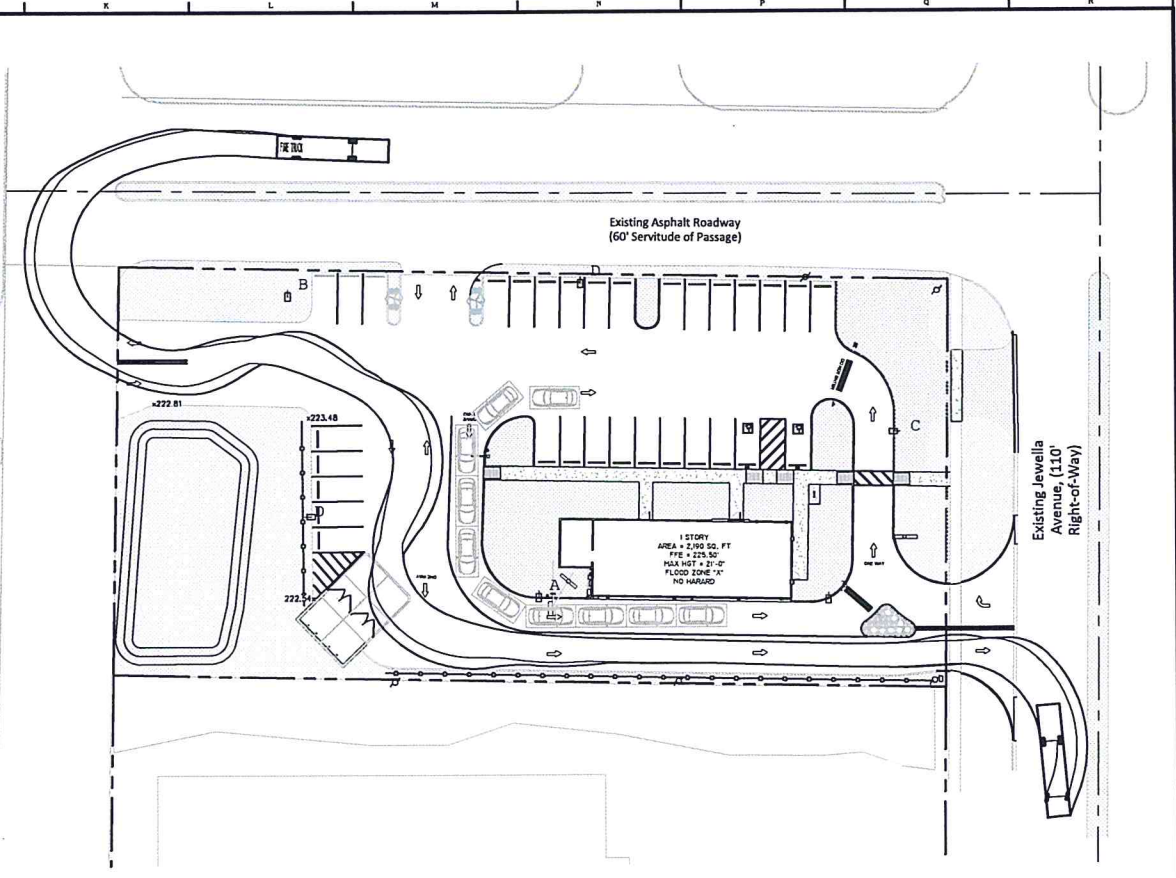

FIRE TRUCK ROUTE
SCALE: 30' = 1'

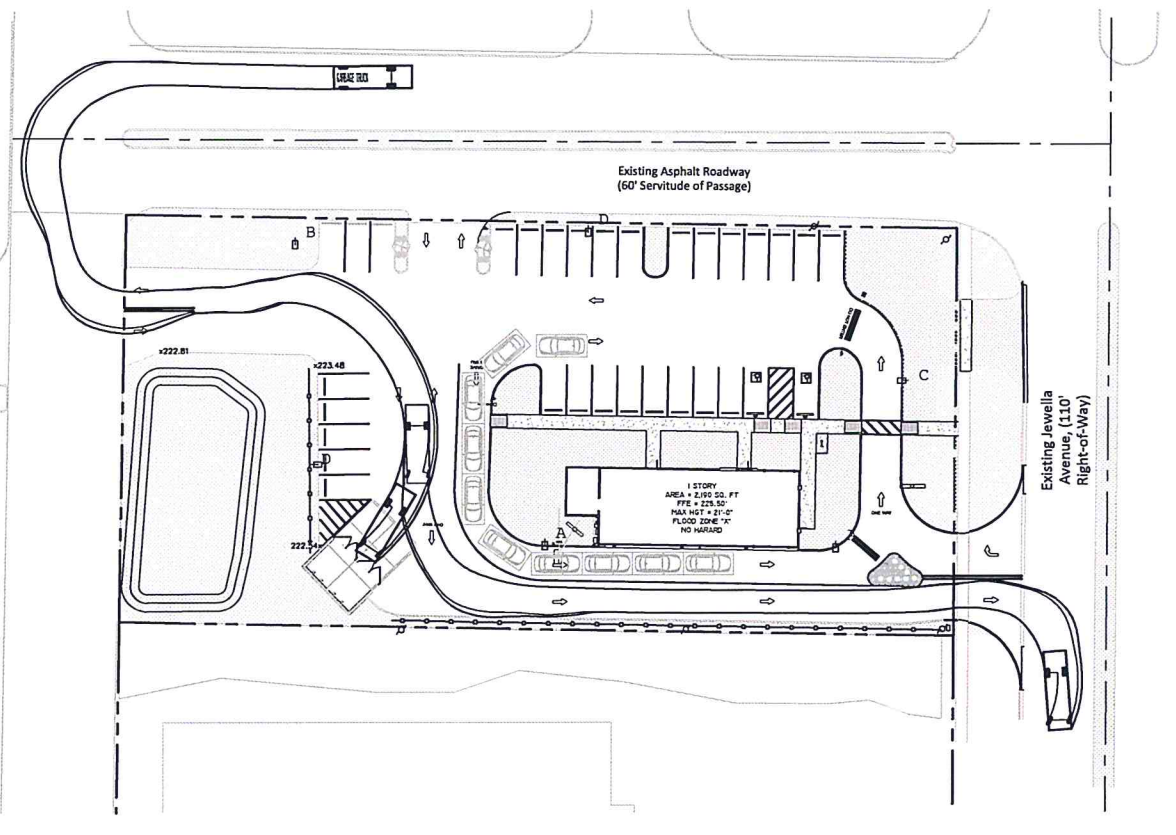

GARBAGE TRUCK ROUTE
SCALE: 30' = 1'

**EXECUTIVE
DIRECTOR
APPROVAL**

3-28-24 *ACA*
Date By

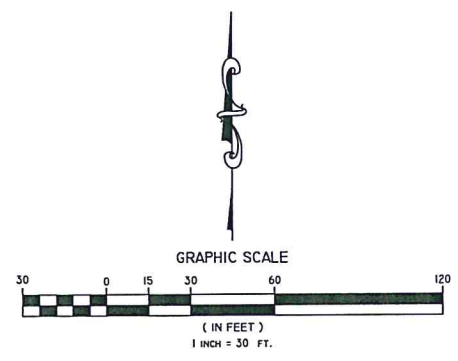

LIS ARCHITECTURE
ENGINEERING
LAND INVESTMENT SERVICES, LLC
CAN. REG. C06680 E.O.S. CERT. LP 00002466001
21430 Palm Beach Blvd
Suite 202, Ocala, FL 32705
Phone: (351) 244-9402
Facsimile: (351) 244-9419

ADAM J. BARNIEY
LA REG. NO. 35692

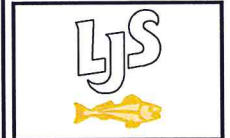

**8928 JEWELLA AVE,
SHREVEPORT,
LOUISIANA 71118**

REVISION		
No.	DATE	DESCRIPTION

DWG DATE: XX-XX-XXXX
DRAWN BY: CB / JC
PROJECT No.: 2023-050
DWG TITLE:

VEHICLE ROUTE
PLAN

SHEET No.
C-3.4

THE LANDSCAPE PLAN SUBMITTED IS THE APPROVED LANDSCAPE PLAN. ANY CHANGES HAVE TO BE SUBMITTED IN WRITING TO THE CITY OF SHREVEPORT FOR APPROVAL.

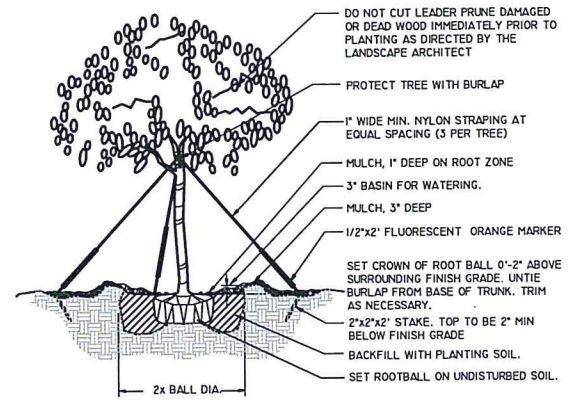

LARGE TREE DETAIL 2" CAL. & UP

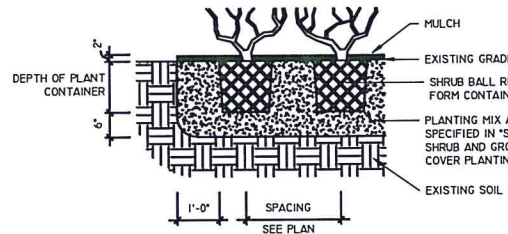

SHRUB PLANTING - SECTION

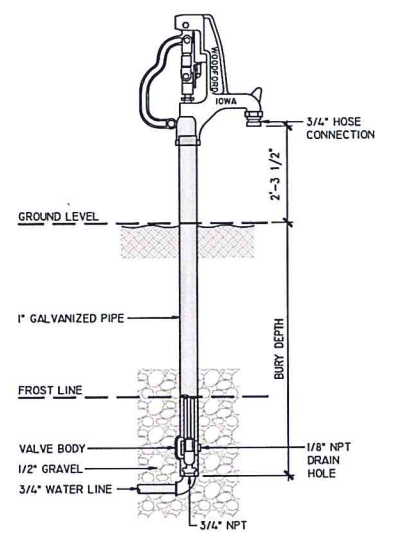

- THESE INSTRUCTIONS DO NOT APPLY TO SANITARY HYDRANTS OR UTILITY HYDRANTS.
- DIG HOLE FOR HYDRANT APPROXIMATELY 2 FEET IN DIAMETER AND DEEPER THAN THE BURY DEPTH.
 - FLUSH GRAVEL, DEBRIS, ETC. OUT OF THE SUPPLY LINE BEFORE CONNECTING HYDRANT.
 - INSTALL HYDRANT WITH DRAIN HOLE BELOW FROST LINE. USE WRENCHES O SUPPLY LINE FITTING AND BRASS VALVE BODY ONLY. THIS AVOIDS OVER TIGHTENING THE HYDRANT ASSEMBLY WHICH COULD AFFECT OPERATION.
 - IF SUPPLY LINE TO THE HYDRANT WILL NOT SUPPORT HYDRANT, USE RE-BAR, LENGTH OF PIPE OR OTHER SUITABLE SUPPORT DRIVEN IN BOTTOM OF PIT TO HELP SUPPORT HYDRANT. BEFORE FILLING EXCAVATION, TURN ON WATER AND CHECK HYDRANT CONNECTION FOR LEAKS.
 - PROVISIONS MUST BE MADE TO ALLOW THE WATER TO DRAIN FROM THE HYDRANT DRAIN HOLE EACH TIME THE HYDRANT IS CLOSED.
 - FILL BOTTOM OF PIT WITH 1/2" GRAVEL TO A MINIMUM OF 3" ABOVE BRASS DRAIN VALVE BODY, TO INSURE ADEQUATE DRAINAGE.
 - IF THE HYDRANT IS INSTALLED INSIDE A STRUCTURE OR CONCRETE DRIVEWAY, CONNECT COPPER DRAIN TUBING TO THE 1/8" NPT DRAIN HOLE AND DIG A REMOTE DRAIN FIELD OUTSIDE THE STRUCTURE FOR THE DRAIN PIPE TO EMPTY INTO. WITHOUT THIS REMOTE PIPING DRAIN FIELD, THE WATER FROM THE HYDRANT DRAINAGE MAY PERCOLATE UP TO THE SURFACE AROUND OR NEAR THE HYDRANT AND WILL DAMAGE THE FLOOR SURFACE OR CAUSE MUDDY AREAS AROUND HYDRANT.
 - SATURATED GROUND IN THE HYDRANT DRAIN FIELD CAN PREVENT THE HYDRANT FROM FULLY DRAINING AND MAY RESULT IN FREEZING. IF THE AREA WHERE THE HYDRANT IS LOCATED IN LOW LYING OR HAS A TENDENCY TO HAVE STANDING WATER, A LARGER DRAIN FIELD OR PIT MAY BE REQUIRED TO PROVIDE THE HYDRANT A PLACE TO DRAIN.

YARD HYDRANT DETAIL

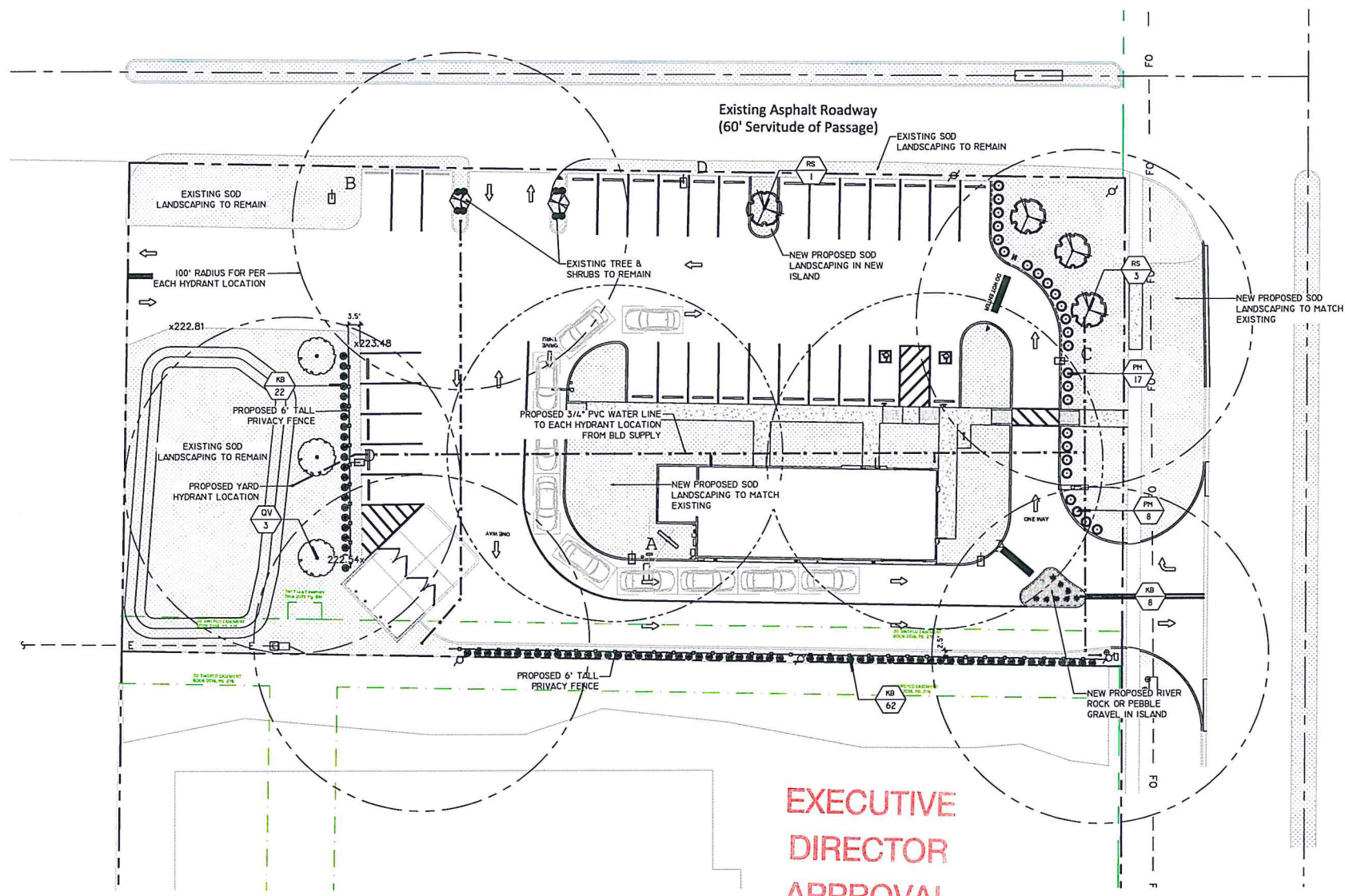

EXECUTIVE DIRECTOR APPROVAL

3.28.24 *AC*
Date By

PLANT_SCHEDULE									
SHRUBS	QTY	COMMON NAME	BOTANICAL NAME	SPECIFICATIONS	SPACING	HEIGHT	SPREAD	NATIVE	REMARKS
KB	83	KOREAN BOXWOOD	BUXUS SINICA VAR	7 GAL	36" O.C.	36" HT.	2'-0"	YES	FULL
PM	25	PENNY MAC HYDRANGEA	HYDRANGEA MACROPHYLLA	10 GAL	48" O.C.	60" HT.	3'-0"	YES	FULL
SHADE TREE	QTY	COMMON NAME	BOTANICAL NAME	SPECIFICATIONS	CAL/DBH	HEIGHT	SPREAD	NATIVE	REMARKS
QV	3	SOUTHERN LIVE OAK	QUERCUS VIRGINIANA	B & B	2-1/2" CAL	10'		YES	
RS	4	RED SHUMARD OAK	QUERCUS SHUMARDII	B & B	2-1/2" CAL	10'		YES	

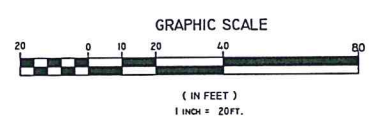

ARCHITECTURE
ENGINEERING
LIS
LAND INVESTMENT SERVICES, LLC
CAN. NO. C05680 SCS CERT. # 0000946001
2577 Hwy 634, Suite 105
Shreveport, Louisiana, LA 70705
Phone: (504) 244-5402
Fax: (504) 244-5419
21430 Palm Beach Blvd
Suite 200, Palm Beach, FL 33480
Phone: (239) 653-5244
Facsimile: (239) 653-5828

ADAM J. BARNIE
LA REG. NO. 33092

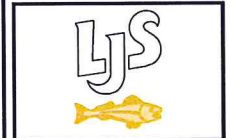

8928 JEWELLA AVE,
SHREVEPORT,
LOUISIANA 71118

REVISION		
No.	DATE	DESCRIPTION

DWG DATE: XX-XX-XXXX
DRAWN BY: CB / JC
PROJECT No.: 2023-050
DWG TITLE:

LANDSCAPING PLAN

SHEET No.
L-1.0

Label	Avg	Max	Min	Avg/Min	Max/Min
EXTENDED	1.12	6.1	0.0	N.A.	N.A.
PARKING LOT & DRIVE-THRU SURFACE	2.94	6.1	0.8	3.68	7.63

LIGHT LEVELS ARE MAINTAINED FOOT-CANDLES, INITIAL LEVELS ARE SLIGHTLY HIGHER

Symbol	Qty	Label	Arrangement	Luminaire Lumens	LLF	CCT	Luminaire Watts	Mounting Height	Description
A	2	A	SINGLE	7560	0.900	4000K	48	27.5	MRM-LED-07L-SIL-2-UNV-DIM-40-70CRI-BR2 / 4SQB3-S11G-25-S-BR2
B	1	B	SINGLE	24620	0.900	4000K	254	27.5	MRM-LED-36L-SIL-3-UNV-DIM-40-70CRI-BR2-IL / 4SQB3-S11G-25-S-BR2
C	1	C	SINGLE	32141	0.900	4000K	213	27.5	MRM-LED-30L-SIL-4-UNV-DIM-40-70CRI-BR2 / 4SQB3-S11G-25-S-BR2
D	2	D	SINGLE	23091	0.900	4000K	254	27.5	MRM-LED-36L-SIL-4-UNV-DIM-40-70CRI-BR2-IL / 4SQB3-S11G-25-S-BR2

NOTE: LIGHT LEVEL AT THE PROPERTY LINES NOT TO EXCEED 1.0 FOOT-CANDLE
POLES ARE 25'-0" ON 2'-6" BASES

LONG JOHN SILVER'S SHREVEPORT, LA
PREPARED BY: JOHN BUJAKE ACCUSERV LIGHTING & EQUIPMENT
877-707-7378 jbukake@accu-serv.com FEBRUARY 15, 2024

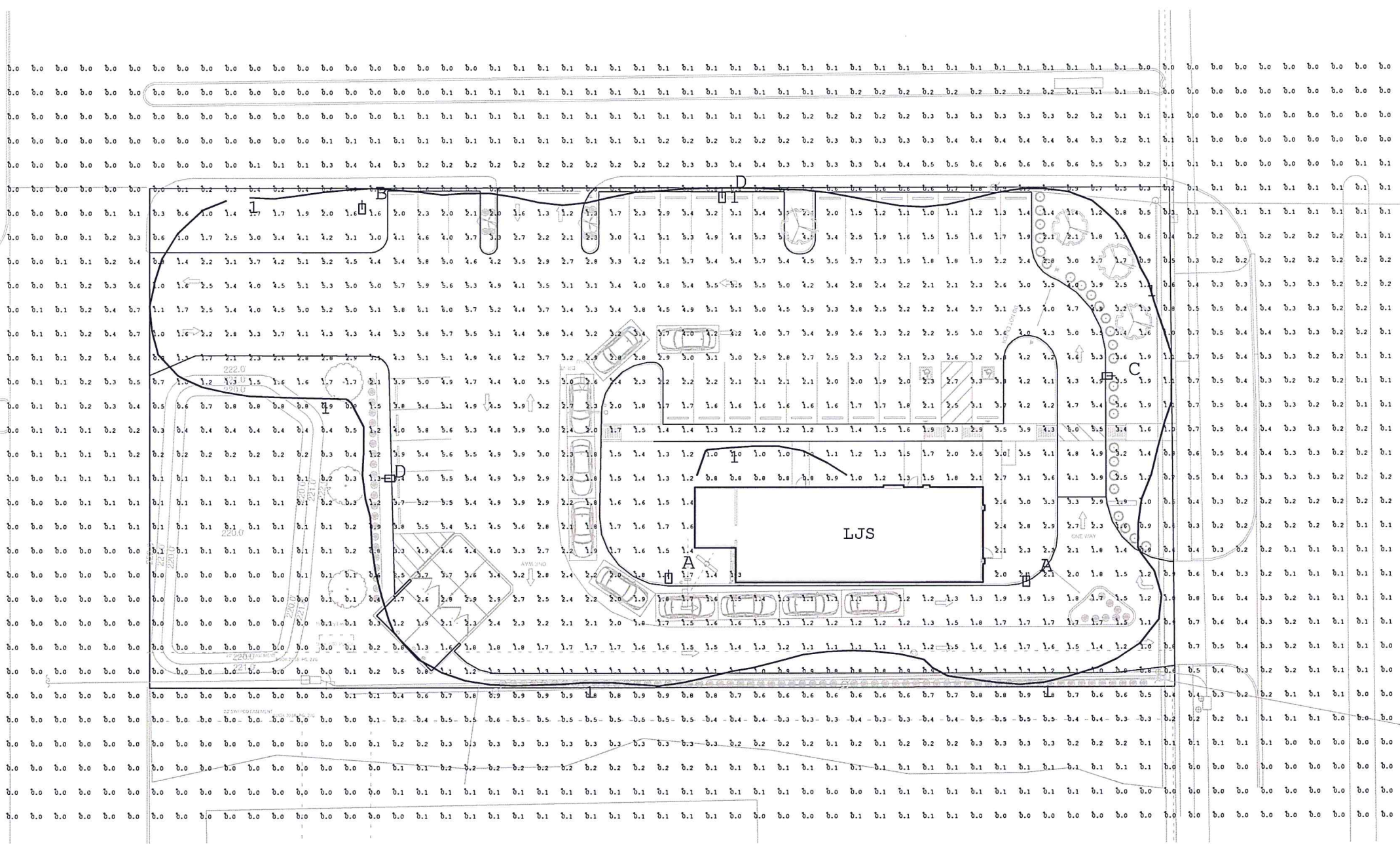

1 PHOTOMETRIC PLAN

SCALE: 3/4" = 1'-0"



EXECUTIVE
DIRECTOR
APPROVAL

3-28-24 *AK* By
Date

LIS ARCHITECTURE ENGINEERING
LUMINAIRE SERVICES, LLC
CA NO. 026860 SOS CERT# LP0002669201
2140 Palm Beach Blvd
West Palm Beach, FL 33411
Phone: (561) 833-3244
Facsimile: (561) 833-3629

ADAM J. BARNIEY
LA REG. NO. 39092

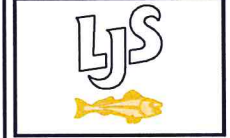

8928 JEWELLA AVE,
SHREVEPORT,
LOUISIANA 71118

REVISION		
No.	DATE	DESCRIPTION

DWG DATE: XX-XX-XXXX
DRAWN BY: CB / JC
PROJECT NO.: 2023-050
DWG TITLE:

ELECTRICAL
PHOTOMETRIC
PLAN

SHEET No.
ES-1.1

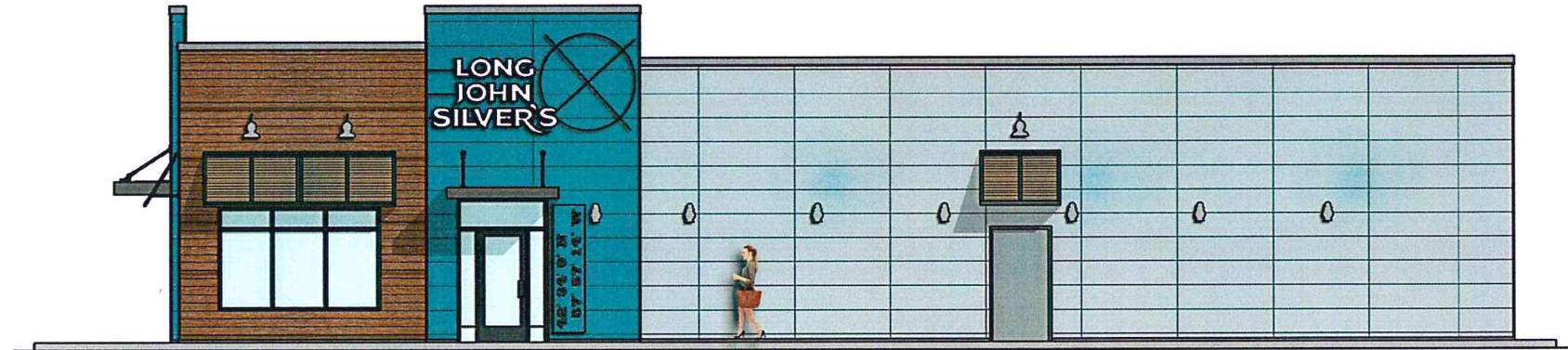

SIDE ENTRANCE ELEVATION (NORTH)

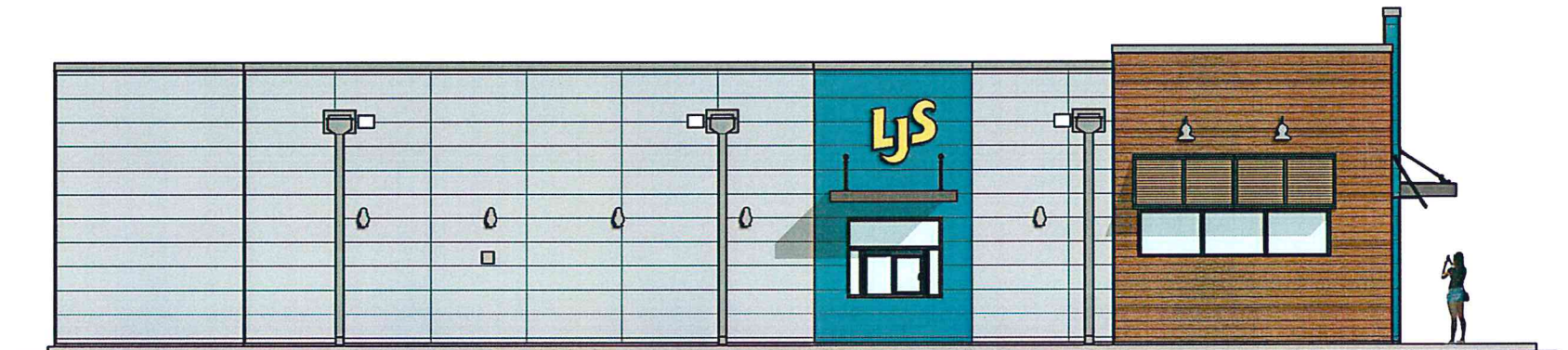

DRIVE-THRU ELEVATION (SOUTH)

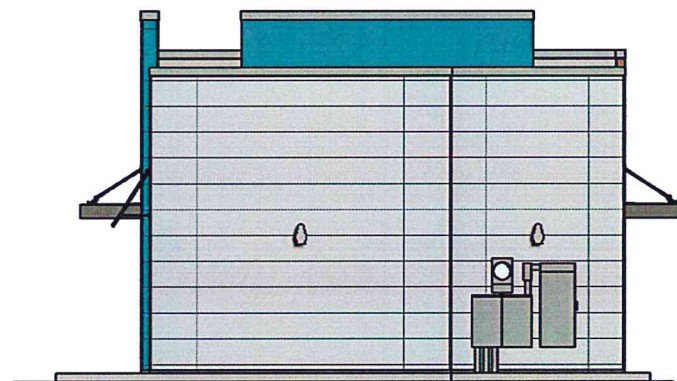

REAR ELEVATION (WEST)



FRONT ELEVATION (EAST)

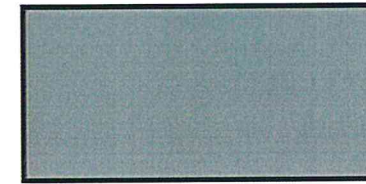

SHERWIN WILLIAMS
SW7074
SOFTWARE
LVR=23



SHERWIN WILLIAMS
SW6509
GEORGIAN BAY
LVR=11

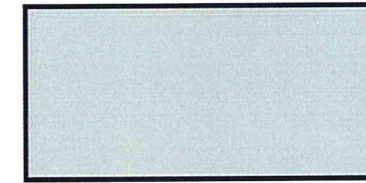

SHERWIN WILLIAMS
SW7072
ONLINE
LVR=45

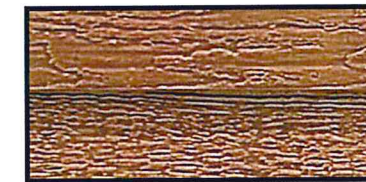

DIAMOND KOTE
PREMIUM SIDING
CHESTNUT
RIGIDSTACK

EXECUTIVE
DIRECTOR
APPROVAL

3-28-24
Date

ACA
By

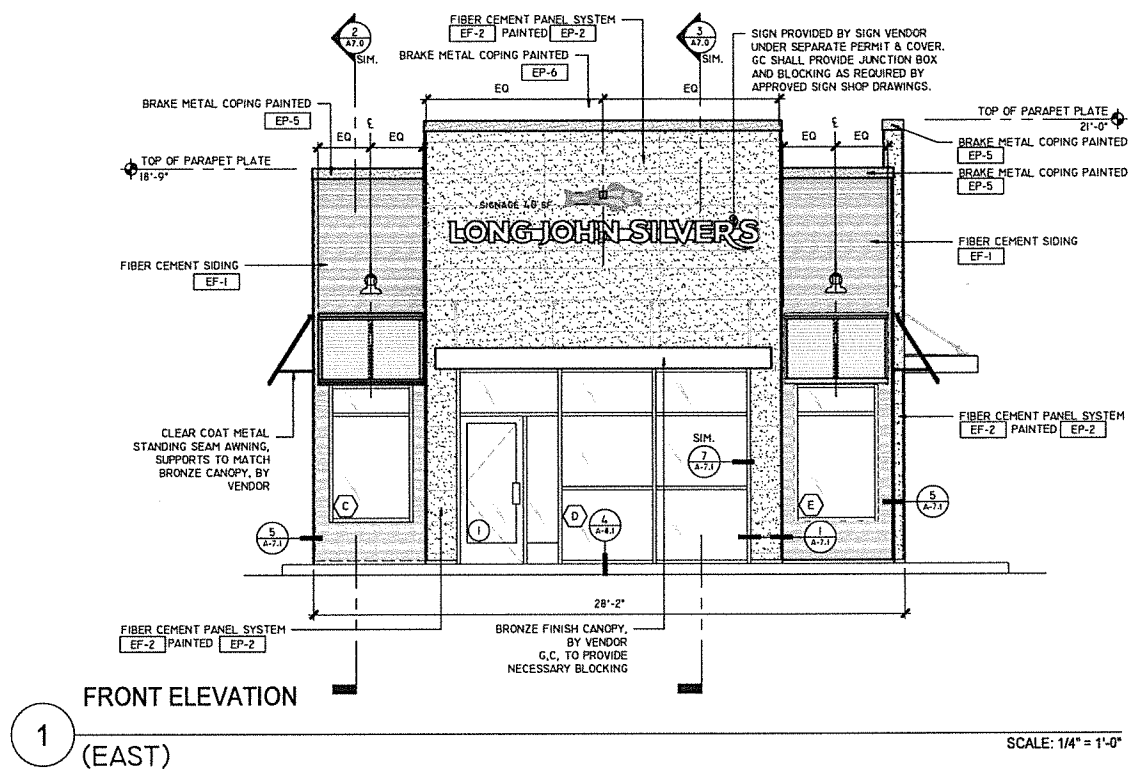

GENERAL EXTERIOR ELEVATION NOTES:

1. CONSIDERATION WILL NOT BE GRANTED FOR ANY ALLEGED MISUNDERSTANDINGS OF THE AMOUNT OF WORK TO BE PERFORMED. TENDER OF PROPOSAL SHALL CONVEY FULL AGREEMENT TO THE ITEMS AND CONDITIONS INDICATED ON THE DRAWINGS. SHOULD THE CONTRACTOR FIND DISCREPANCIES OR OMISSIONS IN THE CONTRACT DOCUMENT OR BE IN DOUBT AS TO THE INTENT THEREOF, THE CONTRACTOR SHALL OBTAIN CLARIFICATION FROM THE ARCHITECT AND/OR THE OWNER'S REPRESENTATIVE PRIOR TO SUBMITTING HIS PROPOSAL FOR WORK.
2. ALL DIMENSIONS ARE SHOWN TO FACE OF FINISH UNLESS NOTES OTHERWISE.
3. WALLS TO STRUCTURAL DECK MUST BE THOROUGHLY SEALED AROUND PENETRATIONS.
4. SEE SHEET T-3.0 FOR EXTERIOR BUILDING FINISH SCHEDULE.
5. SEE SHEET A-8.0 FOR DOOR SCHEDULE & DETAILS.
6. SEE SHEET A-8.1 FOR STOREFRONT GLAZING SCHEDULE & DETAILS.

**ARCHITECTURE
ENGINEERING**

LIS

LAND INVESTMENT SERVICES, LLC
 2672 West State Street, Suite 426
 Metairie, LA 70002
 Phone: (504) 244-6400
 Fax: (504) 244-6419
 Email: lis@lisarch.com

21430 Palm Beach Blvd
 Avondale, LA 70001
 Phone: (504) 835-8929
 Fax: (504) 835-8928

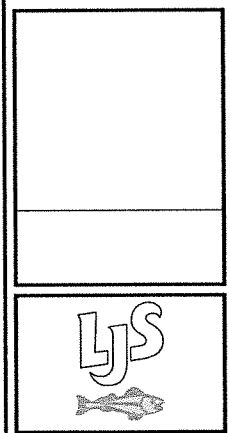

**8928 JEWELLA AVE,
SHREVEPORT,
LOUISIANA 71118**

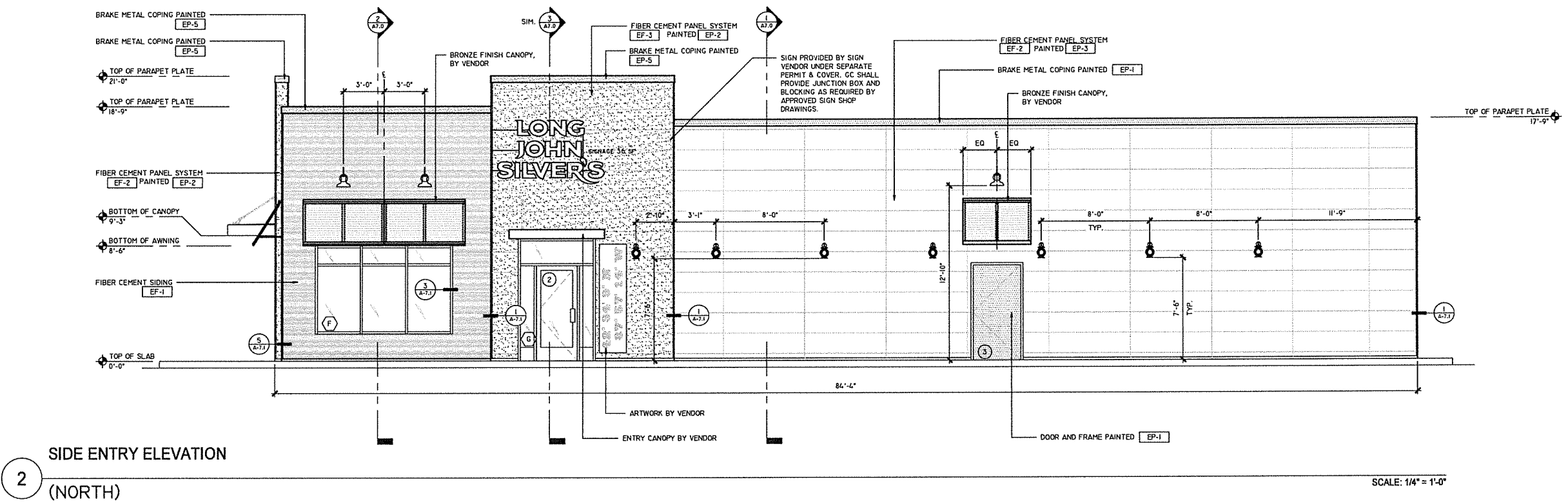

REVISION		
No.	DATE	DESCRIPTION
1	1/28/23	SPECIAL USE CMTS

DWG DATE: XX-XX-XXXX
 DRAWN BY: CB / JC
 PROJECT NO.: 2023-050
 DWG TITLE:

**EXTERIOR
ELEVATIONS**

SHEET No.
A-6.0

